

UBC

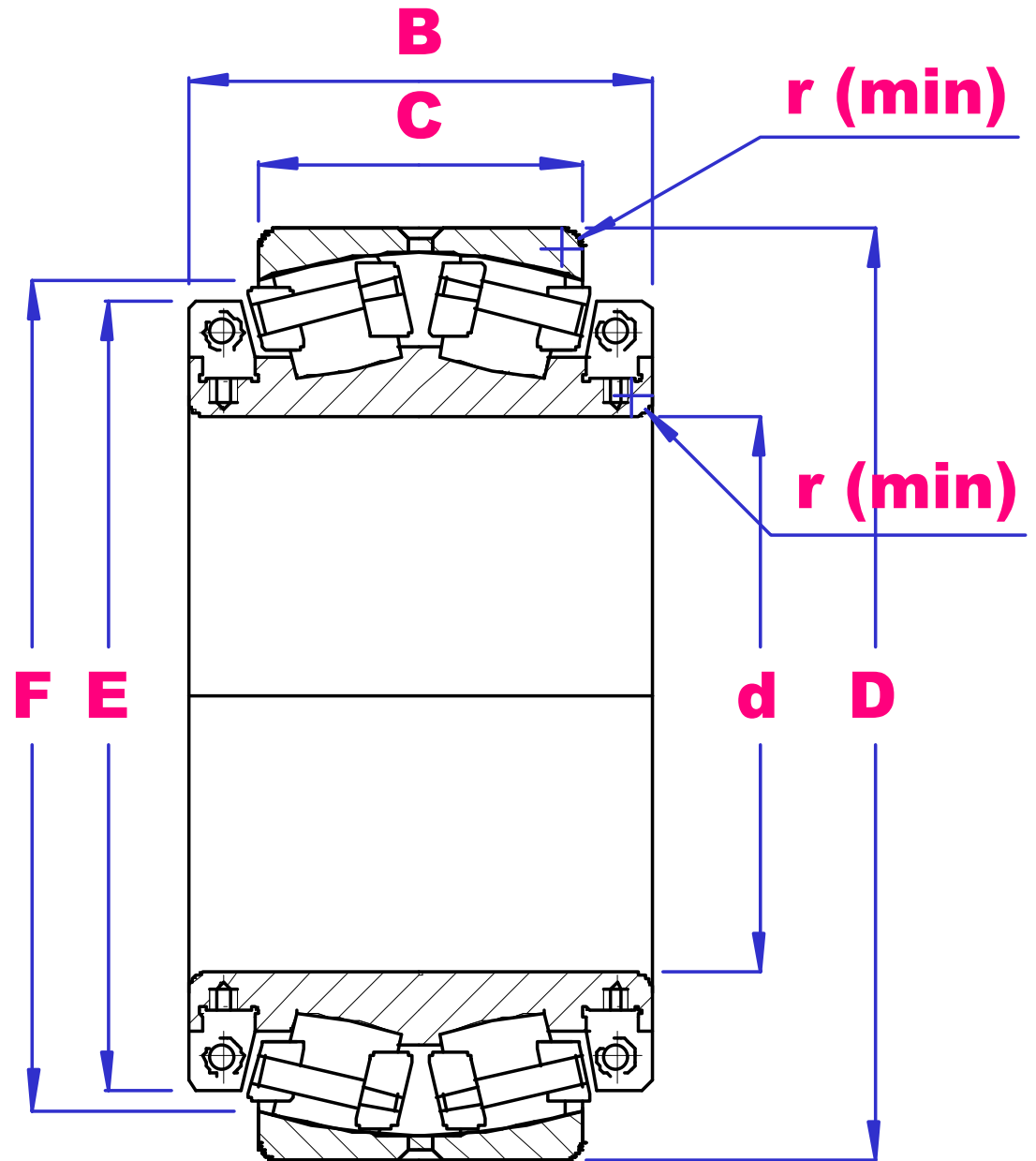

SPLIT SPHERICAL ROLLER BEARINGS



PART NO	d	D	B	r min	C	E	F	LOAD RATING		SPEED RATING (rpm)	WGT kg
								DkN	SkN		
24124D	120	200	142	2.0	80	165	168	540	870	800	18.5
23028D	140	230	102	2.0	53	181	190	350	580	700	15.2
23136X2D	180	300	125	2.1	74	221	247	680	1050	450	32.0
23256D	280	500	260	5.0	176	420	438	2650	4400	350	178
23160D	300	500	240	5.0	160	419	434	1660	4800	330	153
23072D	360	540	220	5.0	134	477	481	2150	4480	280	158
23080D	400	600	240	5.0	148	523	540	2750	5800	250	210
23084D	420	620	238	6.0	150	542	561	2750	5850	240	223
23092X3D	460	700	245	6.0	165	605	635	3150	6500	200	346
230/530X3D	530	780	265	6.0	185	666	704	3400	8100	180	389
230/560X3D	560	870	330	6.0	200	734	785	5020	10500	180	585
241/600D	600	980	515	7.5	375	812	833	10000	21500	150	1370