

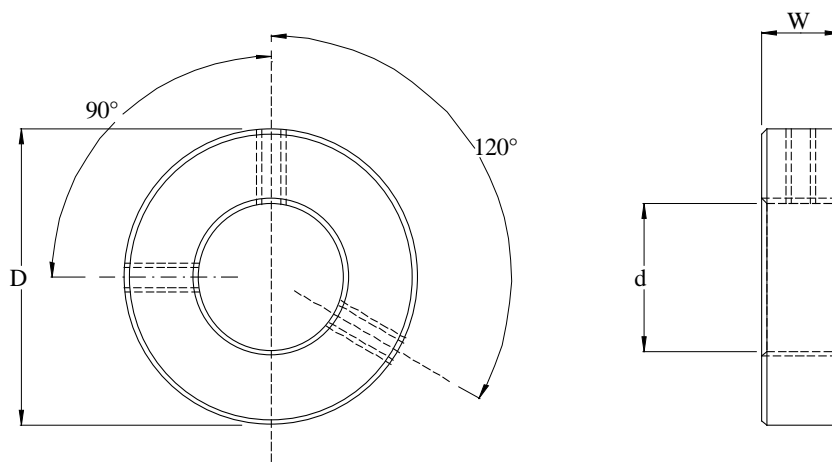

METRIC SHAFT COLLARS



SCM-06, 08, 10 GRUB SCREWS @ 120 DEG
SCM-12 – SCM-75 GRUB SCREWS @ 90 DEG

PART NO	d mm	D mm	W mm	Screw x 2	Weight gm
SCM-06	6	22.2	13.5	M5x0.8	36
SCM-08	8	22.2	13.5	M5x0.8	35
SCM-10	10	22.2	13.5	M5x0.8	32
SCM-12	12	28.6	13.5	M6x1	52
SCM-14	14	28.6	13.5	M6x1	50
SCM-16	16	28.6	13.5	M6x1	45
SCM-20	20	33.3	13.5	M6x1	56
SCM-22	22	38.1	13.5	M6x1	77
SCM-24	24	44.5	15.9	M8x1	130
SCM-25	25	44.5	15.9	M8x1	128
SCM-28	28	44.5	15.9	M8x1	113
SCM-30	30	44.5	15.9	M8x1	102
SCM-32	32	55.5	17.5	M8x1	214
SCM-35	35	55.5	17.5	M8x1	192
SCM-38	38	63.5	18.3	M10x1.25	238
SCM-40	40	63.5	18.3	M10x1.25	265
SCM-42	42	63.5	18.3	M10x1.25	247
SCM-45	45	69.9	18.3	M10x1.25	309
SCM-48	48	76.2	20.0	M10x1.25	431
SCM-50	50	76.2	20.0	M10x1.25	405
SCM-60	60	90	20.0	M10x1.25	540
SCM-70	70	100	20.0	M10x1.25	607
SCM-75	75	110	22.0	M12X1.5	845

STANDARD MATERIAL = MILD STEEL ZINC PLATED
FOR 304 STAINLESS STEEL, ADD SUFFIX '-SS' TO PART NUMBER

TOLERANCE = d - 0.01 + 0.01mm

D - 0.1 + 0.1 mm

W - 0.1 + 0.1 mm