

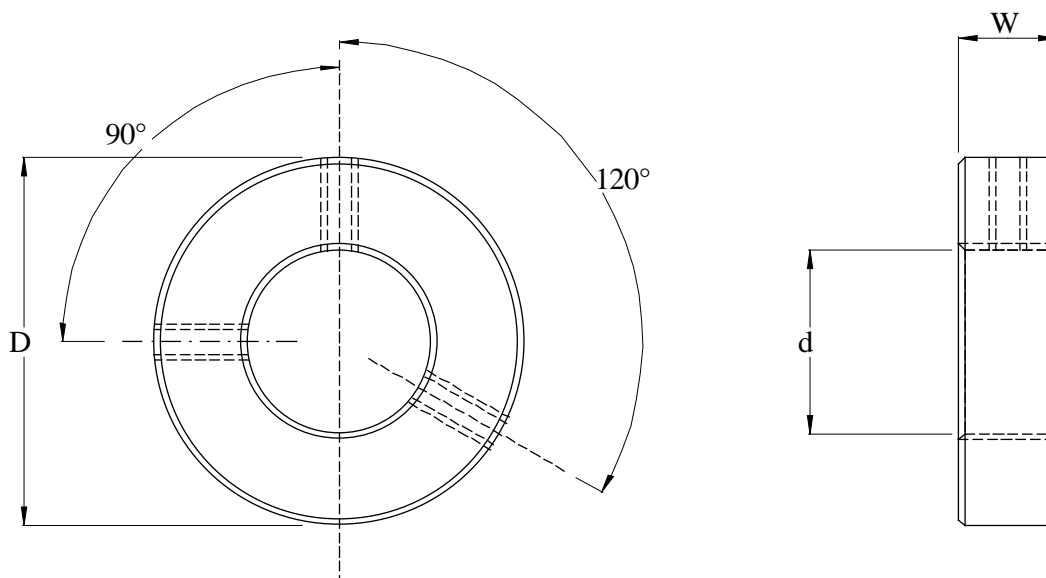

INCH SHAFT COLLARS



SCI-1/4, 5/16, 3/8 GRUB SCREWS @ 120 DEG
SCI-7/16 – SCI-3 GRUB SCREWS @ 90 DEG

PART NO	d in	D in	W mm	Screw x 2	Weight gm
SCI-1/4	0.25	0.875	13.5	M5X0.8	37
SCI-5/16	0.3125	0.875	13.5	M5X0.8	35
SCI-3/8	0.375	0.875	13.5	M5X0.8	32
SCI-7/16	0.4375	1.125	13.5	M6x1	55
SCI-1/2	0.50	1.125	13.5	M6x1	52
SCI-5/8	0.625	1.125	13.5	M6x1	45
SCI-3/4	0.75	1.312	13.5	M6x1	60
SCI-7/8	0.875	1.5	13.5	M6x1	76
SCI-1	1.00	1.75	15.9	M8x1	126
SCI-1.1/8	1.125	1.75	15.9	M8x1	110
SCI-1.1/4	1.25	2.187	17.5	M8x1	216
SCI-1.3/8	1.375	2.187	17.5	M8x1	193
SCI-1.1/2	1.5	2.37	18.3	M8x1	237
SCI-1.5/8	1.625	2.5	18.3	M8x1	253
SCI-1.3/4	1.75	2.75	18.3	M10x1.25	313
SCI-2	2.00	3.0	20.7	M10x1.25	398
SCI-2.1/4	2.25	3.23	23.8	M10x1.25	494
SCI-2.1/2	2.50	3.47	25.4	M10X1.25	573
SCI-3	3.00	4.22	28.6	M12X1.5	967

STANDARD MATERIAL = MILD STEEL ZINC PLATED
FOR 304 STAINLESS STEEL, ADD SUFFIX '-SS' TO PART NUMBER

TOLERANCE = d - 0.01 + 0.01mm

D - 0.1 + 0.1 mm

W - 0.1 + 0.1 mm