



UBC

CSK SERIES

ONE WAY/SPRAG

BALL BEARINGS



Quality
Endorsed
Company
ISO 9001:2000
LIC QEC20818

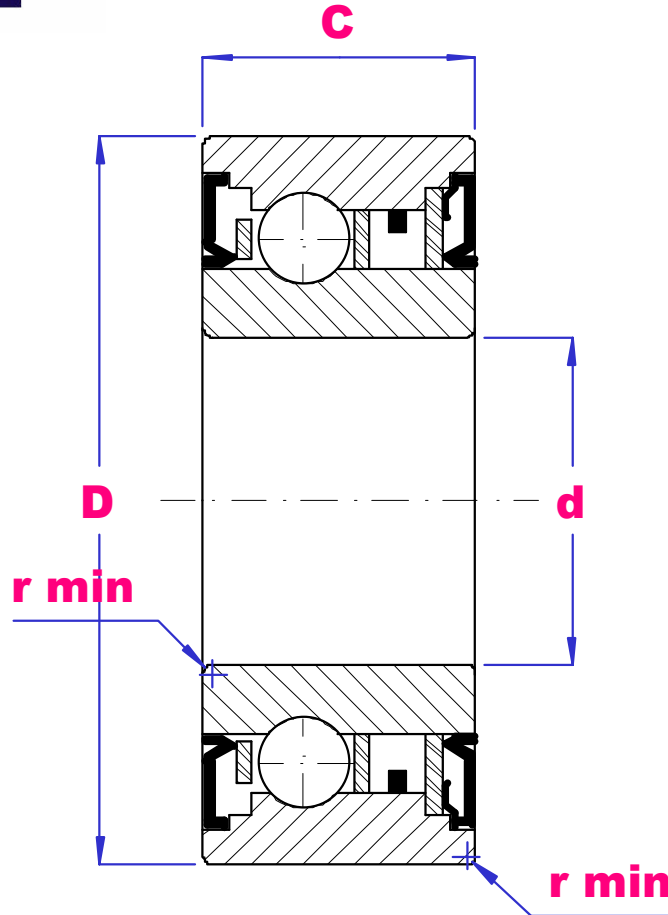

PART NO	d	D	C	r min	TORQUE Nm	LOAD RATING		SPEED RPM	WGT g
						DkN	SkN		
CSK15	15	35	16	0.6	29	7.4	3.42	8400	70
CSK17	17	40	17	0.6	43	7.9	3.81	7350	90
CSK20	20	47	19	1.0	61	9.4	4.46	6000	145
CSK25	25	52	20	1.0	78	10.7	5.46	5200	175
CSK30	30	62	21	1.1	140	11.7	6.45	4200	270
CSK35	35	72	22	1.1	173	12.6	7.28	3600	400
CSK40	40	80	27	1.1	260	15.5	12.25	3000	600