

UNI-HUB

MULTI PCD

REPAIR ADAPTER

**DRILLED TO SUIT THE
FOLLOWING**

108MM/4.25"PCD

114.3MM/4.5"PCD

140MM/5.5"PCD

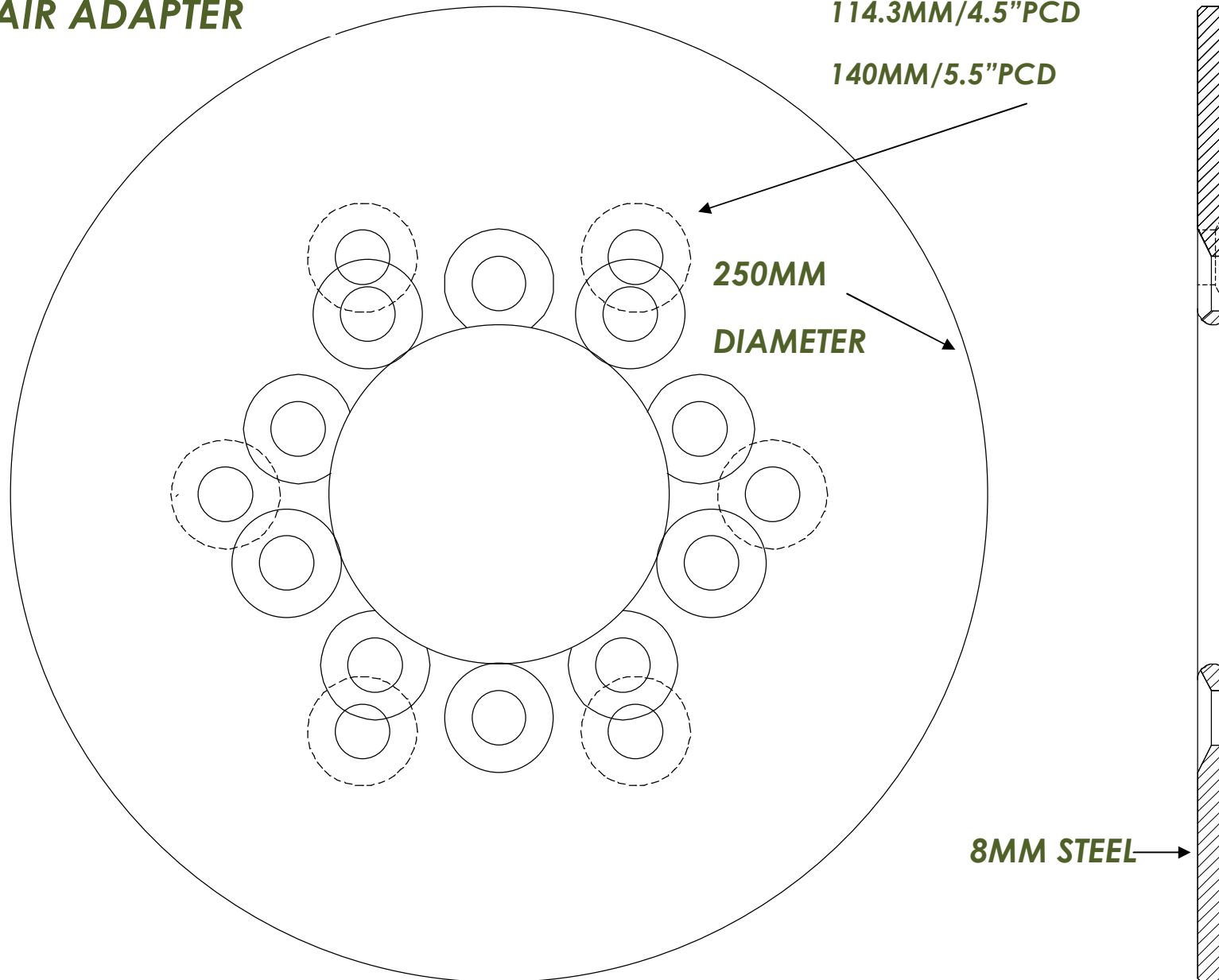

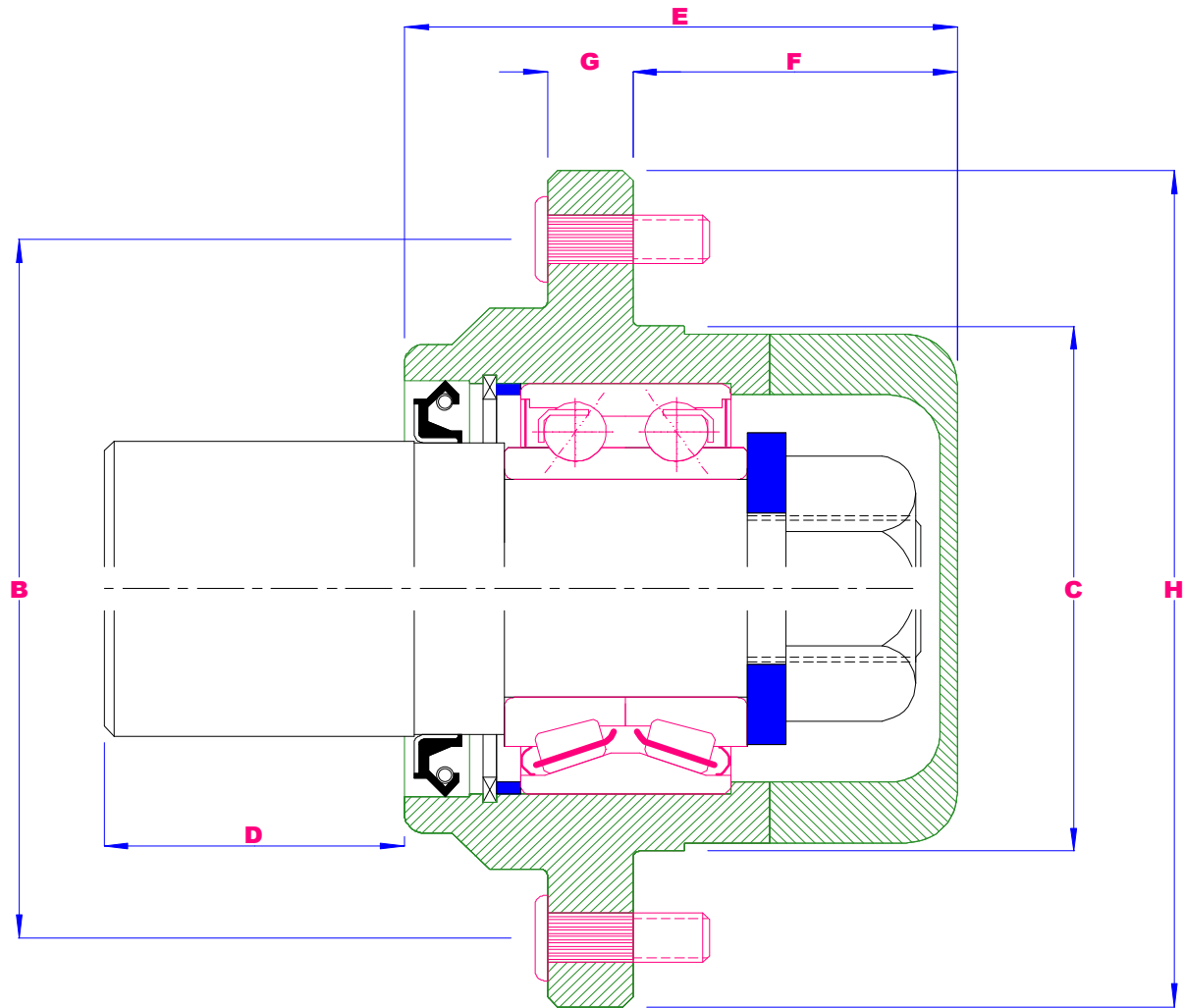

PART NO	BEARING ID	SUIT AXLE	B PCD	STUD SIZE	F mm	E mm	C mm	H mm	G mm	WGT KG
UNI-HUB 1	37mm	1,2,3	108mm 4.25" (HT)	5 M12X1.5	30	84	72	151	13	3.1
UNI-HUB 2	37mm	1,2,3	114.3mm 4.5" (FORD)	5 1/2" UNF	43	104	72	151	13	3.1
UNI-HUB 3	39mm	4	139.7mm 5.5" (L/C)	6 1/2" UNF	33	85	86.5	200	19.5	5.1
UNI-HUB 4	PILOT BORE	PILOT BORE	108/114.3mm 4.25"/4.5"	5 7/16" UNF	33	60	-	150	13	3.7
UNI-HUB 5	PILOT BORE	PILOT BORE	139.7mm 5.5"	6 1/2" UNF	33	85	86.5	200	19.5	5.5
UNI-HUB 6	70mm	6	205mm (BEDFORD)	6 M18X1.5	95	163	160	250	25	14.6

AXLE TYPE
1

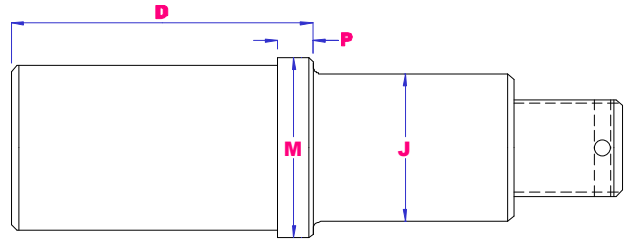
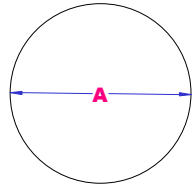

AXLE TYPE
2

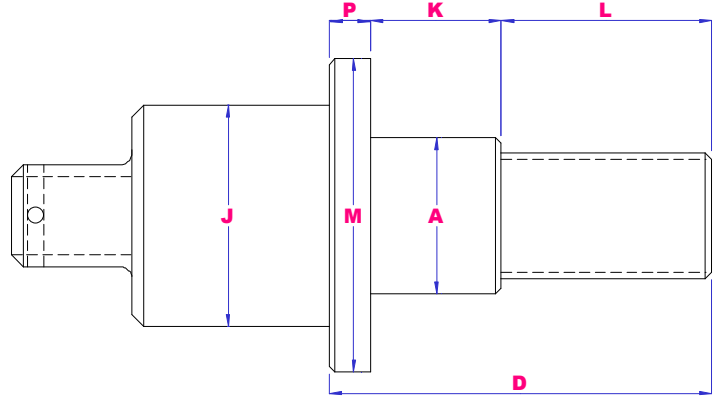
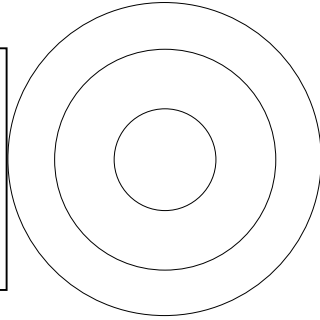

AXLE TYPE
3

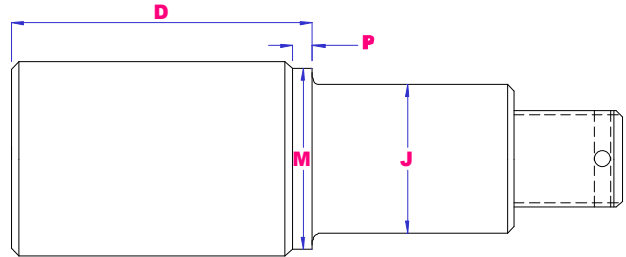
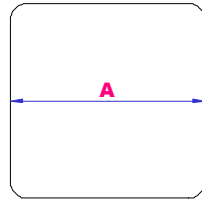

PART NO	LENGTH TO HUB D	AXLE TYPE	AXLE SECTION A	J	K	L	M	P	CAPACITY PER WHEEL	WGT KG
AXLE 1	125	1	40mm ROUND	37	-	-	45	9	375	1.88
AXLE 2	62	2	30mm M24x2	37	30	27	50	9	300	1.14
AXLE 3	183	3	50mm SQUARE	37	-	-	-	-	1000	4.18
AXLE 4	186	3	55mm SQUARE	39	-	-	50	10	1700	5.08
AXLE 6	290	3	90mm SQUARE	70	-	-	89	25	6000	23.5

UNI- HUB
CAST IRON
380X6 WHEEL

