

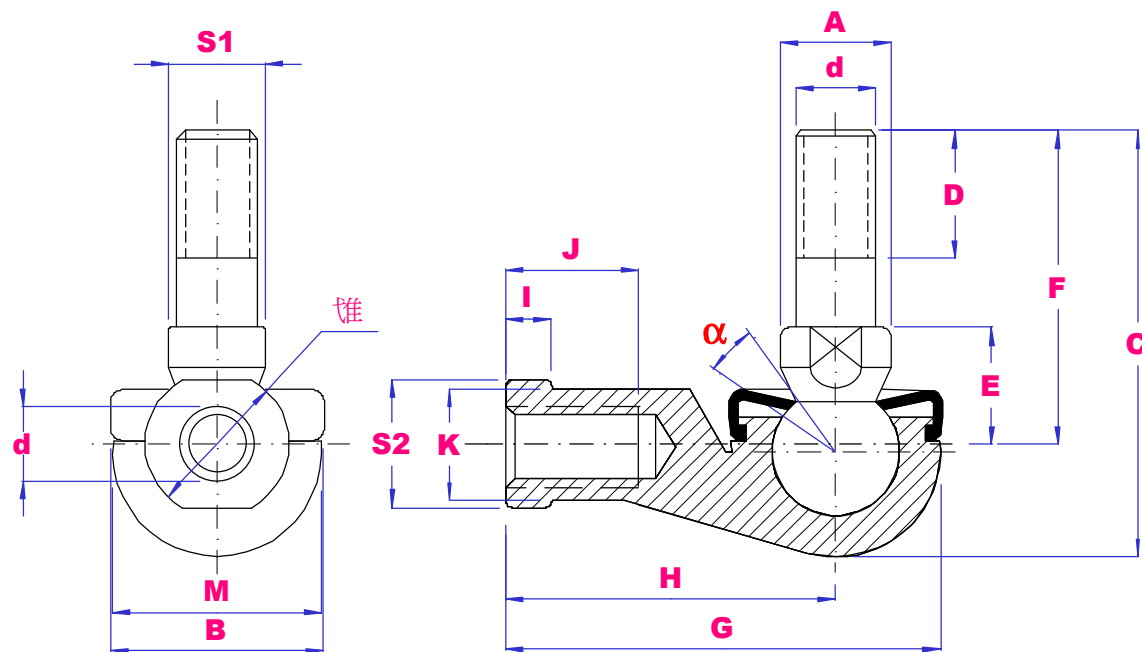

SQY INCH STUD TYPE RODENDS STEEL / ZINC ALLOY



PART NO	G UNF	A	B	C	D	E	F	G	H	I	J	K	L	M	S1	S2	α deg	Load kN Stat	Wgt g
SQY3/16RS	10-32	9	19	29	8	10	21	35	27	4	14	9	11	16	7	9	25	2.2	26
SQY1/4-RS	1/4-28	10	20	35.5	11	11	26	40	30	5	14	10	13	19	8	11	25	3.5	39
SQY5/16-RS	5/16-24	12	24	42.5	12	14	31	48	36	5	17	12.5	16	23	10	14	25	6.6	68
SQY3/8-RS	3/8-24	14	30	50.5	15	17	37	57	43	6.5	21	15	19	27	11	17	25	10	112
SQY7/16-RS	7/16-20	17	32	57.5	17	19	42	66	50	6.5	25	17.5	22	31	15	19	25	16	164
SQY1/2-RS	1/2-20	19	38	73.5	22	21.5	56	75	57	8	26	20	25	35	17	22	25	19	254
SQY5/8-RS	5/8-18	22	44	79.5	23	23.5	60	84	64	8	32	22	27	39	19	22	20	26	336
SQY3/4-RS	3/4-12	23	45	90	25	26.5	68	93	71	10	34	25	31	44	20	27	20	33	464

THE FULL RANGE IS AVAILABLE IN LEFT HAND THREAD USE PART NO SQYL-RS