

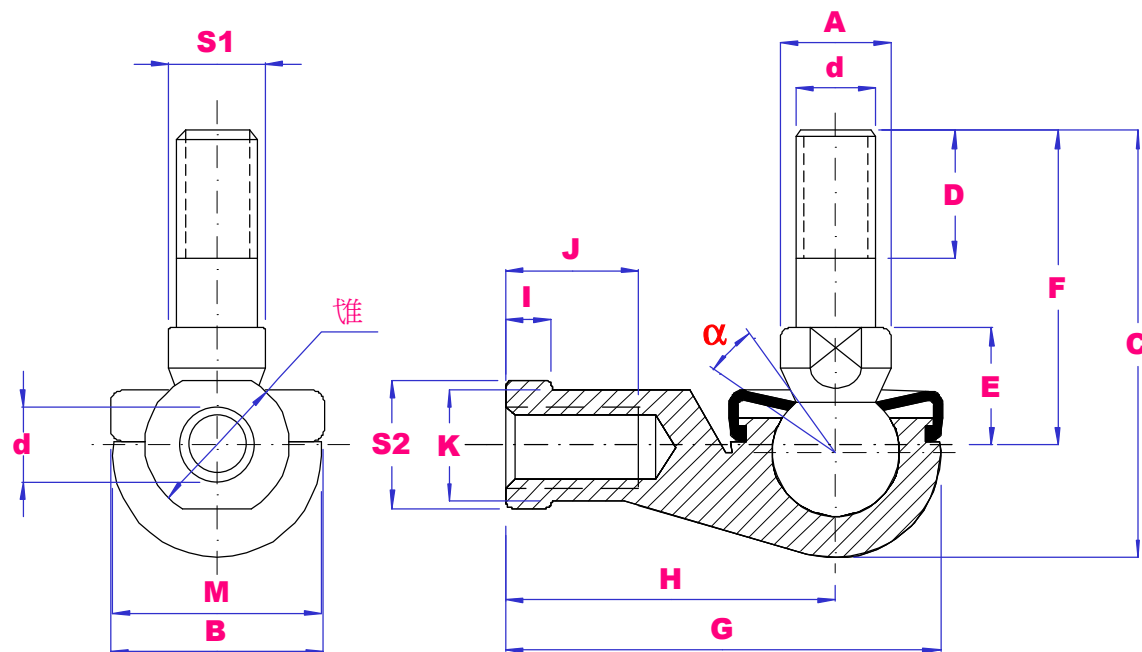

SQ METRIC STUD TYPE RODENDS STEEL / ZINC ALLOY



PART NO	d 6H	A	B	C	D	E	F	G	H	I	J	K	L	M	S1	S2	α deg	Load kN Stat	Wgt g
SQ5-RS	M5X0.8	9	19	29	8	10	21	35	27	4	14	9	11	16	7	9	25	2.2	26
SQ6-RS	M6X1	10	20	35.5	11	11	26	40	30	5	14	10	13	19	8	11	25	3.5	39
SQ8-RS	M8X1.25	12	24	42.5	12	14	31	48	36	5	17	12.5	16	23	10	14	25	6.6	68
SQ10-RS	M10X1.25	14	30	50.5	15	17	37	57	43	6.5	21	15	19	27	11	17	25	10	112
SQ10-RSB5	M10X1.5	14	30	50.5	15	17	37	57	43	6.5	21	15	19	27	11	17	25	10	112
SQ12-RS	M12X1.25	17	32	57.5	17	19	42	66	50	6.5	25	17.5	22	31	15	19	25	16	164
SQ12-RSB5	M12X1.75	17	32	57.5	17	19	42	66	50	6.5	25	17.5	22	31	15	19	25	16	164
SQ14-RS	M14X1.5	19	38	73.5	22	21.5	56	75	57	8	26	20	25	35	17	22	25	19	254
SQ16-RS	M16X1.5	22	44	79.5	23	23.5	60	84	64	8	32	22	27	39	19	22	20	26	336
SQ18-RS	M18X1.5	23	45	90	25	26.5	68	93	71	10	34	25	31	44	20	27	20	33	464
SQ20-RS	M20X1.5	27	50	90	25	27	68	99	77	10	35	27.5	34	44	24	30	20	45	538
SQ22-RS	M22X1.5	27	52	95	26	28	70	109	84	12	41	30	37	50	24	32	16	48	713

THE FULL RANGE IS AVAILABLE IN LEFT HAND THREAD USE PART NO SQL-RS