

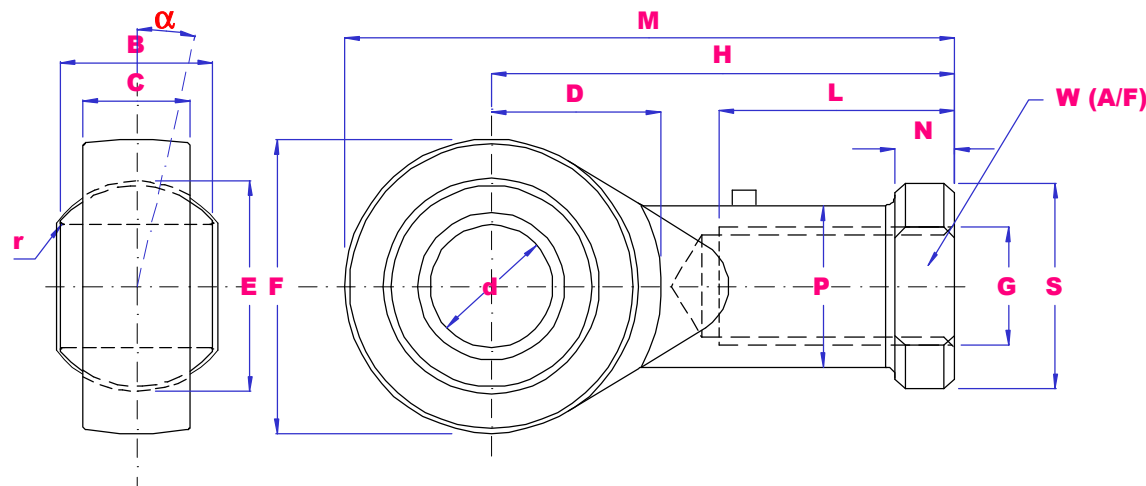

## METRIC FEMALE NARROW RODENDS STEEL / STEEL



PART NO	d	B	E	C	F	G 6H	H	L	M	N	D	W	P	S	r min	α deg	Load kN		Wgt g
																	Dyn	Stat	
SI5E	5	6	10	4.5	21	M5X0.8	30	11	40.5	5	11.5	10	10	13	0.3	13	3.4	8.1	21
SI6E	6	6	10	4.5	21	M6X1	30	11	40.5	5	11.5	11	11	13	0.3	13	3.4	8.1	21
SI8E	8	8	13	6.5	24	M8X1.25	36	15	48	5	13	13	13	16	0.3	15	5.5	12.9	39
SI10E	10	9	16	7.5	29	M10X1.5	43	20	57.5	6.5	15	16	16	19	0.3	12	8.1	17.6	61
SI12E	12	10	18	8.5	34	M12X1.75	50	23	67	7	18	18	19	22	0.3	10	10	24.5	96
SI15ES	15	12	22	10.5	40	M14X2	61	30	81	8	21	21	21	26	0.3	8	16	36	162
SI17ES	17	14	25	11.5	46	M16X2	67	34	90	10	23	27	25	29	0.3	10	21	45	233
SI20ES	20	16	29	13.5	53	M20X1.5	77	40	103.5	10	25.5	30	28	34	0.3	9	30	60	324
SI25ES	25	20	35.5	18	64	M24X2	94	48	126	12	33	36	35	42	0.6	7	48	83	625
SI30ES	30	22	40.7	20	73	M30X2	110	56	146.5	15	37.5	46	42	50	0.6	6	62	110	976
SI35ES	35	25	47	22	82	M36X3	125	60	166	15	40	55	48	58	0.6	6	79	146	1520
SI40ES	40	28	53	24	92	M39X3	142	65	188	18	47	60	52	65	0.6	7	99	180	2060
SI45ES	45	32	60	28	102	M42X3	145	65	196	20	52	65	58	70	0.6	7	127	240	2720
SI50ES	50	35	66	31	112	M45X3	160	68	216	20	57	70	62	75	0.6	6	156	290	3570
SI60ES	60	44	80	39	135	M52X3	175	70	242.5	20	68.5	80	70	88	1.0	6	245	450	5630
SI70ES	70	49	92	43	160	M56X4	200	80	280	20	81	85	80	98	1.0	6	313	610	8330
SI80ES	80	55	105	48	180	M64X4	230	85	320	25	91	95	95	110	1.0	6	400	750	13040

**THE FULL RANGE IS AVAILABLE IN LEFT HAND THREAD USE PART NO SIL-E/S**