

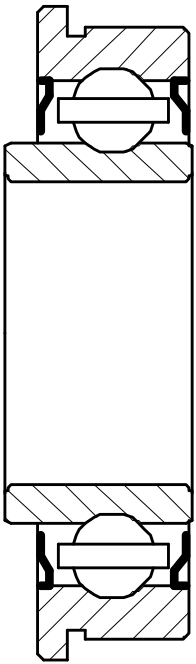

INDEX



PRODUCT	PAGE
TYPICAL DRAWINGS	1-2
SEMI PRECISION BEARINGS	3
PRECISION CONVEYOR BEARINGS	4
PRESSED METAL & INJECTION MOULDED BEARINGS	5
SKATE WHEEL BEARINGS	6
SPECIAL DESIGN BEARINGS	7
BALL TRANSFER UNITS	8
CONVEYOR ROLLER END CAPS	9
CONVEYOR ROLLER DRIVE SPROCKETS	10
BS & ASA CHAIN	11
UNIVERSAL JOINTS	12
SPROCKET COUPLING	13
SELF ALIGNING WASHERS	14
SHAFT COLLARS METRIC	15
SHAFT COLLARS INCH	16
INCH – METRIC CONVERSION	17
METRIC – INCH CONVERSION	18



PAGE 3

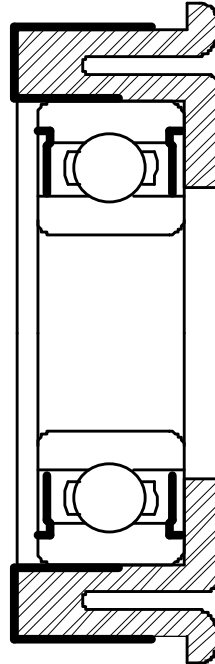
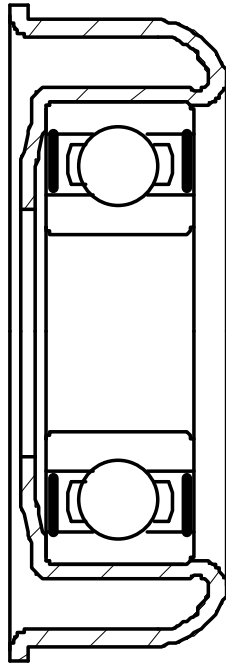

PAGE 4

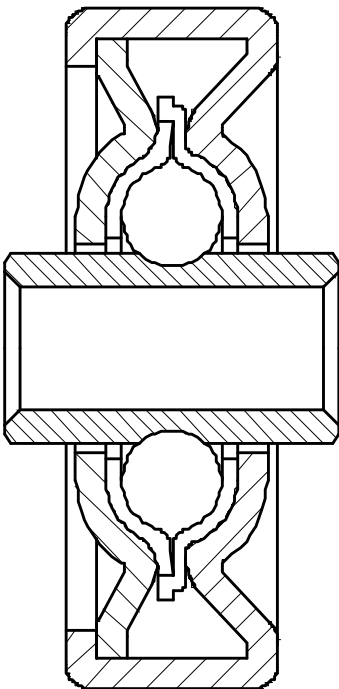
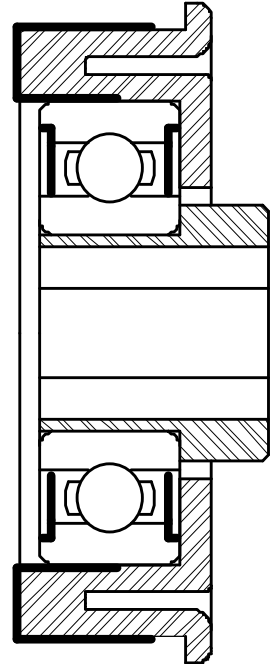

PAGE 6

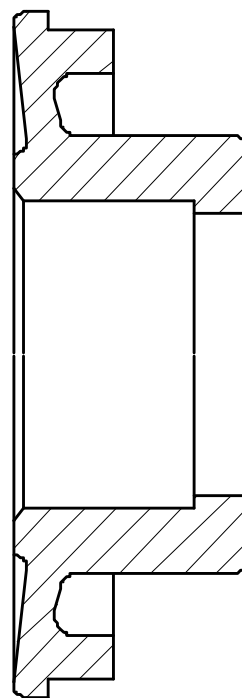
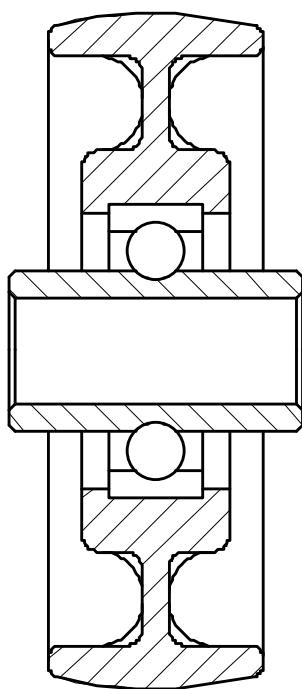

PAGE 9

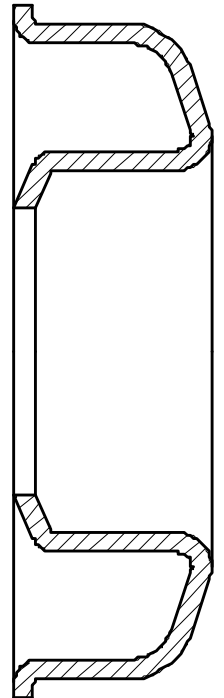

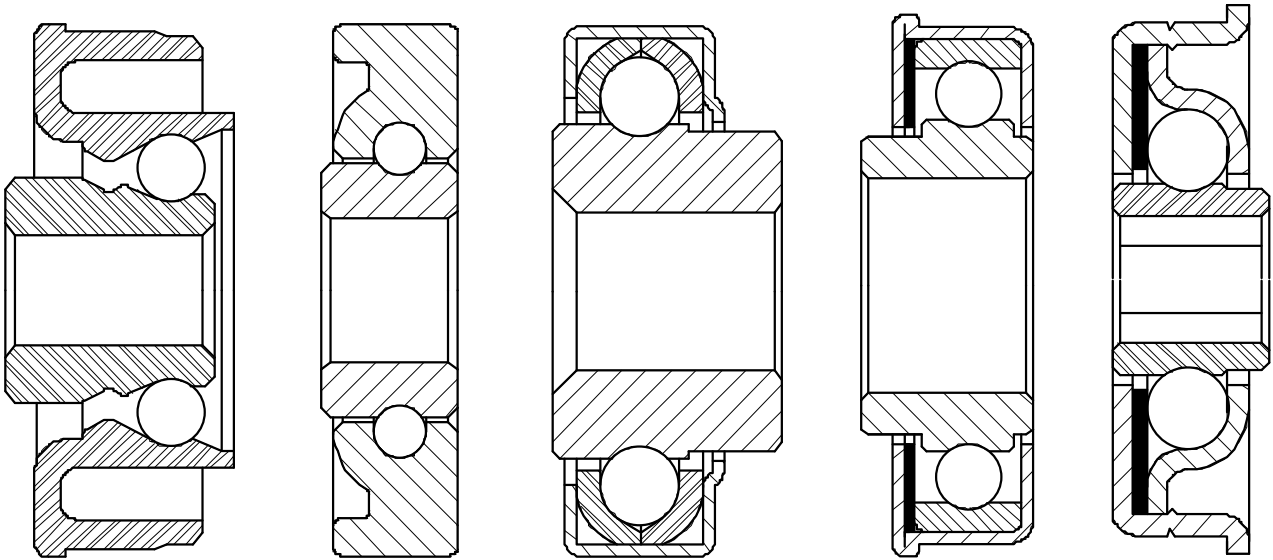

PAGE 5

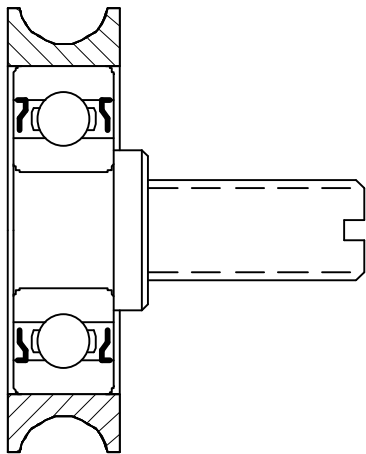

PAGE 7

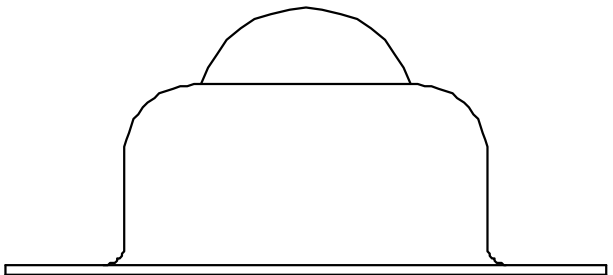

PAGE 8

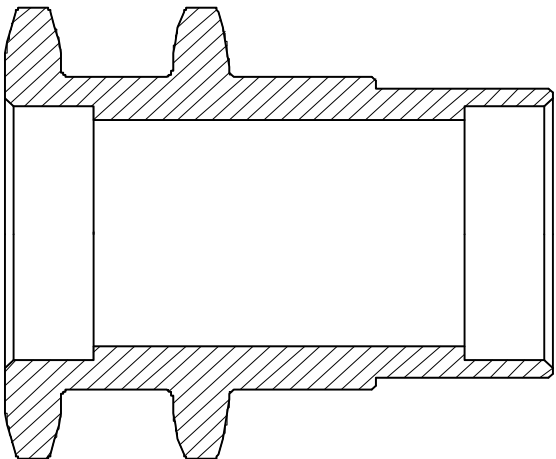

PAGE 10

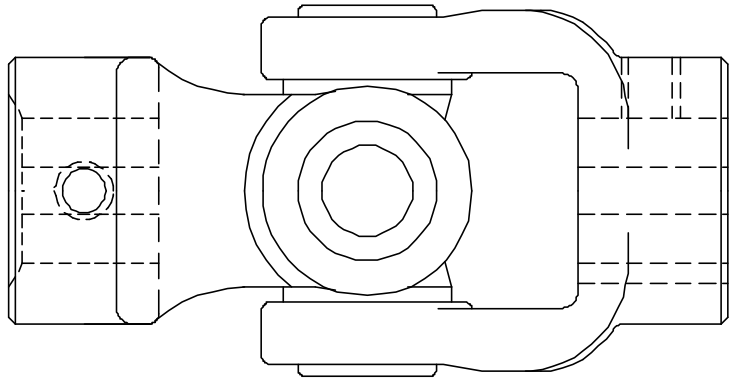

PAGE 12



UBC

SEMI PRECISION BALL BEARINGS



Quality
Endorsed
Company
ISO 9001:2000
LIC QEC20818

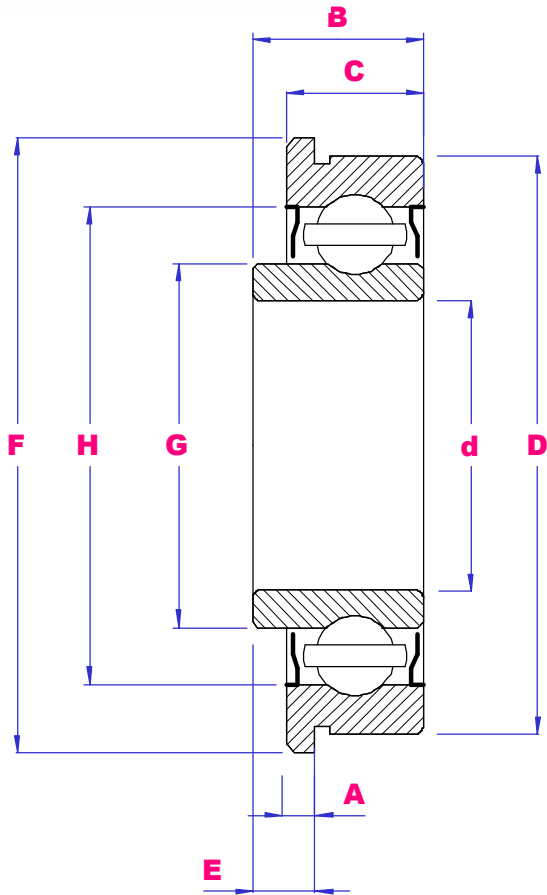

Rubber seals

Zinc plated

PART NO	d(in)	D(in)	A(mm)	B(mm)	C(mm)	E(mm)	F(mm)	G(mm)	H(mm)
S18054SP	5/16	1-1/8	1.58	9.50	7.80	3.17	31.00	17.00	25.00
S18064SP	3/8	1-1/8	1.58	9.50	7.80	3.17	31.00	17.00	25.00
S18074SP	7/16	1-1/8	1.58	9.50	7.80	3.17	31.00	17.00	25.00
S18084SP	1/2	1-1/8	1.58	9.50	7.80	3.17	31.00	17.00	25.00
S22064SP	3/8	1-3/8	1.58	11.90	10.50	3.17	38.00	23.00	31.00
S22084SP	1/2	1-3/8	1.58	11.90	10.50	3.17	38.00	23.00	31.00
S22104SP	5/8	1-3/8	1.58	11.90	10.50	3.17	38.00	23.00	31.00
S22124SP	3/4	1-3/8	1.58	11.90	10.50	3.17	38.00	23.00	31.00
S35201SP	20mm	35mm	1.58	11.90	10.50	3.17	38.00	23.00	31.00
S28104SP	5/8	1-3/4	1.58	14.90	13.80	3.40	47.00	27.00	37.00
S28124SP	3/4	1-3/4	1.58	14.90	13.80	3.40	47.00	27.00	37.00
S28164SP	1	1-3/4	1.58	14.90	13.80	3.40	47.00	27.00	37.00
S32124SP	3/4	2	2.50	15.50	12.70	5.00	54.00	32.00	42.00
S32164SP	1	2	2.50	15.50	12.70	5.00	54.00	32.00	42.00



UBC

PRECISION CONVEYOR BEARINGS



Quality
Endorsed
Company
ISO 9001:2000
LIC QEC20818

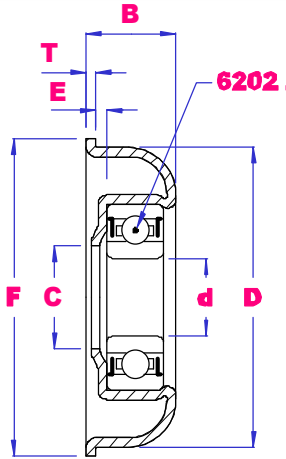

TYPE 1

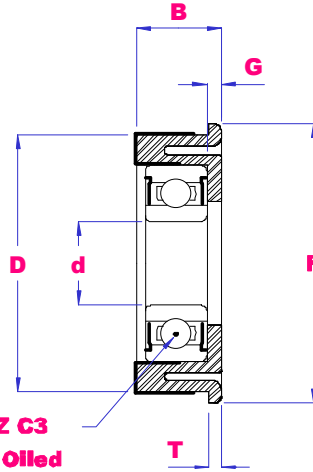

TYPE 2

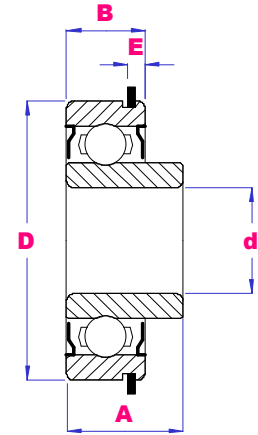

TYPE 3

PART NO	TYPE	d mm	D mm	A mm	B mm	F mm	G mm	E mm	T mm	WGT g
RLR51-*	2	15*	46.5	-	15.1	50	3.2	-	2.1	52
250-50-*	1	15*	47.5	-	16.3	49.7	-	3.85	1.32	79
250-59-*	1	15*	54.8	-	16.3	58.8	-	2.1	2.1	99
250-60-*	1	15*	56.5	-	16.3	59.8	-	2.1	2.1	101
S55301H	3	5/8 HEX	55	25	13	55	-	-	-	221
S43161PP	3	16.4	42.85	17.95	12.1	47.3	-	2.45	-	93
SH72361PB-**	1	20**	71.45	-	23.3	76.2	-	-	2.3	227
SH83361PB-**	1	20**	82.9	-	23.3	88.2	-	-	2.3	256

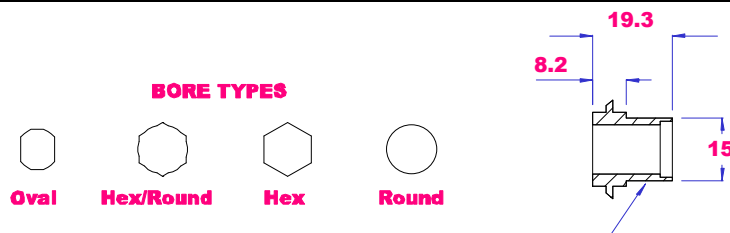

*** BORE / BEARING INSERT SIZES AVAILABLE**

OVAL 8MM
 HEX 3/8", 7/16", 9/16".
 ROUND 10,12,13,14,15,16,17mm. 3/8", 1/2", 5/8".

**** BORE / BEARING INSERT SIZES AVAILABLE**

HEX 3/8", 7/16", 9/16", 5/8", 11/16".
 ROUND 10,12,13,14,15,17,20,25,30,35mm. 1/2", 5/8", 3/4", 7/8", 1".



UBC

PRESSED METAL - - INJECTION MOULDED BEARINGS



Quality
Endorsed
Company
ISO 9001:2000
LIC QEC20818

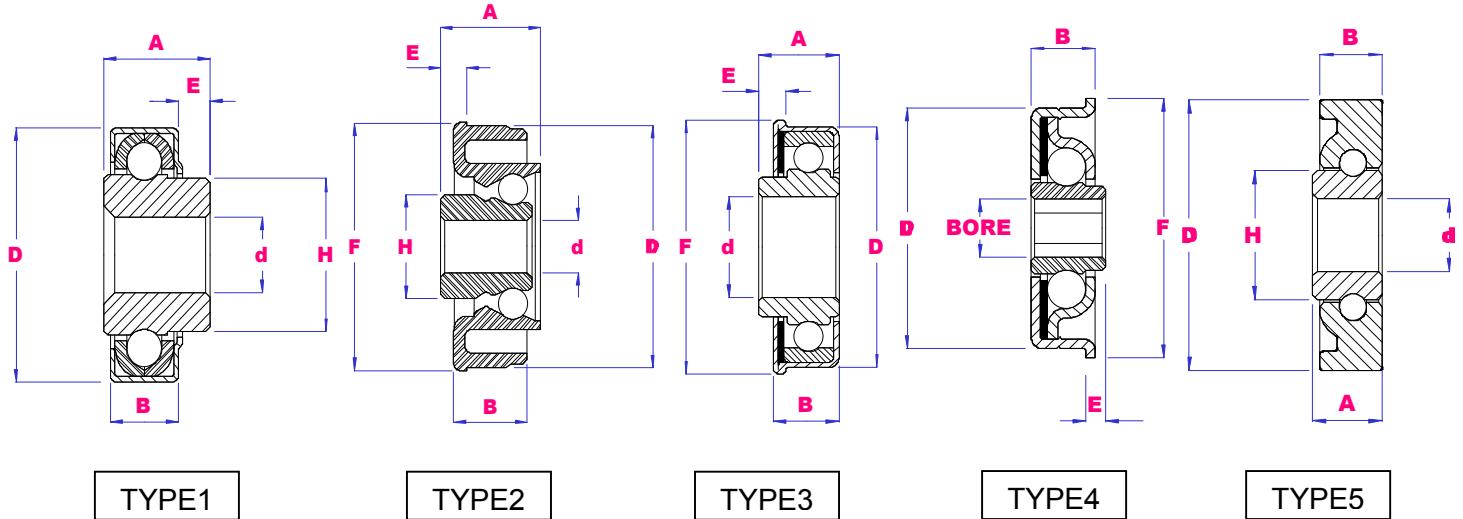

PART NO	MAT	TYPE	d mm	D mm	A mm	B mm	E mm	F mm	H mm	Wgt g
RW08	STEEL	3	8.1	28.7	19.7	9.5	4.8	31.8	17.5	49
S29081PE	STEEL	5	8.1	28.9	7.7	7.1	-	-	13.9	26
BE090	NYLON	2	8.2	21.8	11.9	11.7	2.5	24.8	13.2	6
PB4908	STEEL	1	8.4	49.2	22.3	14.5	4.4	-	12.5	90
ACUR10	STEEL	4	10HEX	47.5	15.4	12.1	4.6	50.9	16.5	90
BE115	STEEL	4	10.5	45.7	22.3	13.5	9.2	47.6	19.9	115
S47101UGP	STEEL	4	10.5	47.5	18.9	14.4	5.8	50.8	17.8	97
N48101UG	NYLON	2	10.5	47.6	21.3	15.8	5.5	50.0	20.8	36
BE145	NYLON	2	10.5	48.7	21.3	15.8	5.5	50.2	20.8	39
ACUR11	STEEL	4	11HEX	47.5	15.8	12.1	6.0	50.9	16.9	84
ACUR12	STEEL	4	12	47.5	15.8	12.1	6.0	50.9	16.9	81
S43121UG	STEEL	4	12.5	43	18.7	13.8	4.9	-	19.1	84
WB5/8	STEEL	3	15.9	34.9	11.4	9.9	2.95	38.0	22.2	47
S54161UG	STEEL	1	16.5	54	23.95	14.6	8.5	-	-	229
WB3/4	STEEL	3	19.2	34.9	11.4	9.9	2.95	38.0	22.2	42
WB20	STEEL	3	20.1	34.9	11.4	9.9	2.95	38.0	22.2	42
WB20MM	STEEL	3	20.1	47	15.9	12.9	5.2	51.5	28.1	106
WB1X2	STEEL	3	25.6	50.8	15.9	12.9	3.85	54.0	31.2	114



UBC

SKATE WHEEL BEARINGS

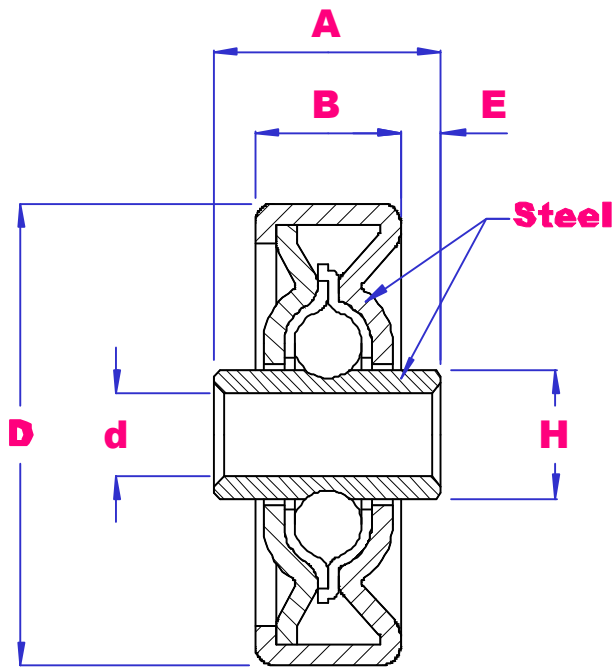

TYPE 1

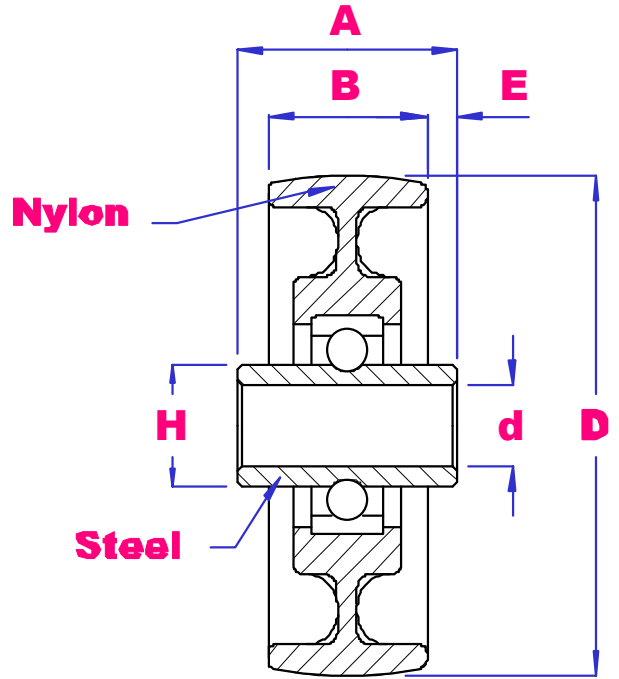

TYPE 2

PART NO	TYPE	d mm	D mm	A mm	B mm	E mm	H mm	Wgt g
SNW50061	2	6.5	50.2	22.1	16.1	3.0	11.9	34
PB4908	1	8.35	49.2	22.2	14.5	4.4	12.5	90
SNW50081	2	8.35	50.2	22.1	16.1	3.0	11.9	30



UBC

SPECIAL DESIGN BEARINGS



Quality Endorsed Company
ISO 9001:2000
LIC QEC20818

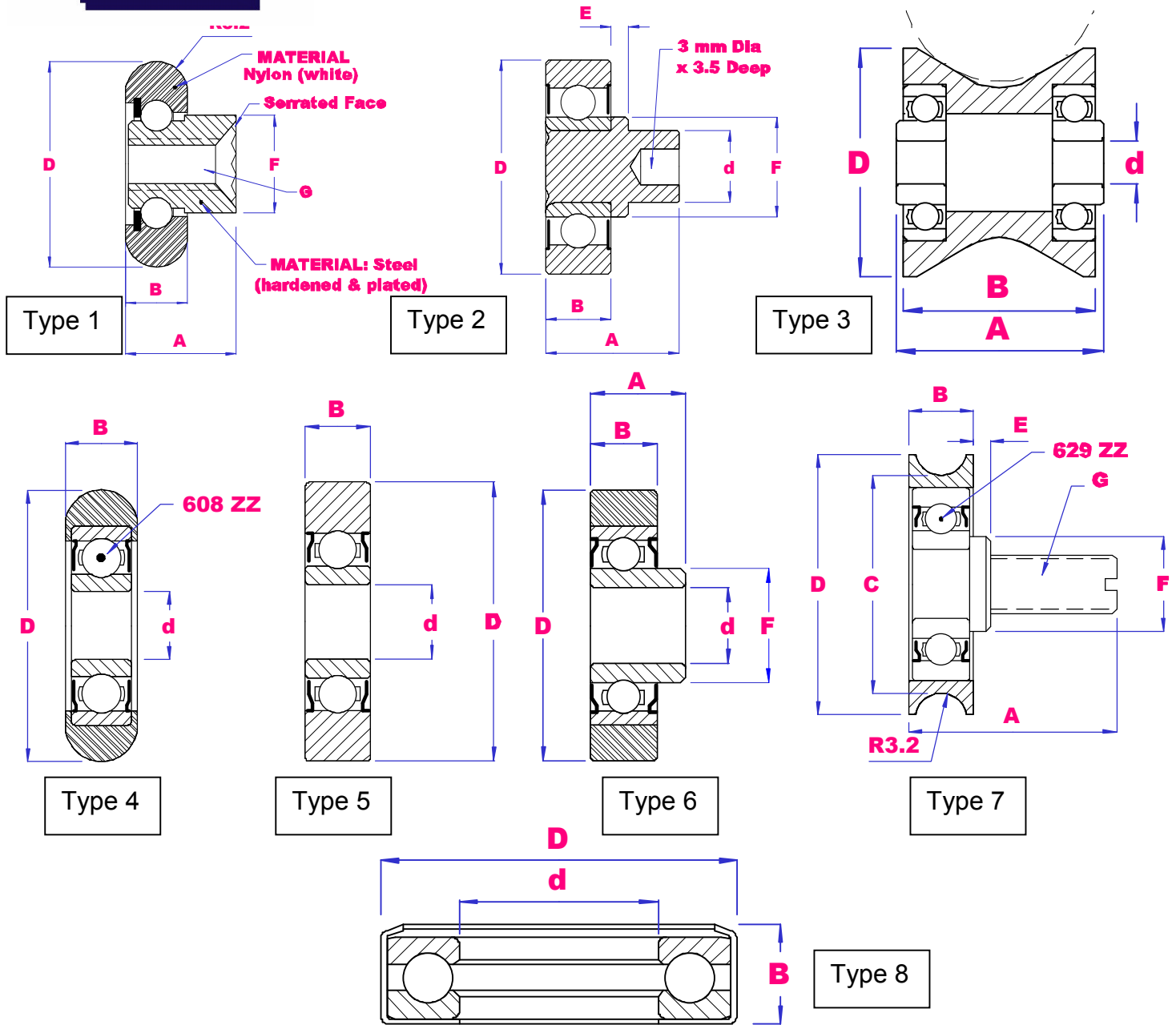

PART NO	TYPE	OD MAT	d mm	D mm	A mm	B mm	C mm	E mm	F mm	G	r mm	Wgt g
N19032	1	NYLON	-	19.5	12.7	6.4	-	-	9.5	5/32 BSW	3.2	8
S19051P	2	STEEL	4.7	18.7	12.3	5.0	-	2.5	11.0	-	-	11
VWM606	3	STEEL	6	32	29	27	-	-	-	-	13.5	68
VWM606N	3	NYLON	6	32	29	27	-	-	-	-	13.5	35
608NW	4	NYLON	8	31.5	8.5	7	-	-	-	-	3.2	15
S30081P	5	STEEL	8	30	7	7	-	-	-	-	-	29
BAC29N	6	NYLON	8	28.6	10	7.15	-	-	11.8	-	-	15
SS35081	7	STAINLESS STEEL	-	34.8	27.7	9.4	30.4	1.1	12.7	M8x1.25	3.2	54
T18010	8	STEEL	15.9	28.6	-	8.15	-	-	-	-	-	18



UBC

BALL TRANSFER UNIT BT254-1

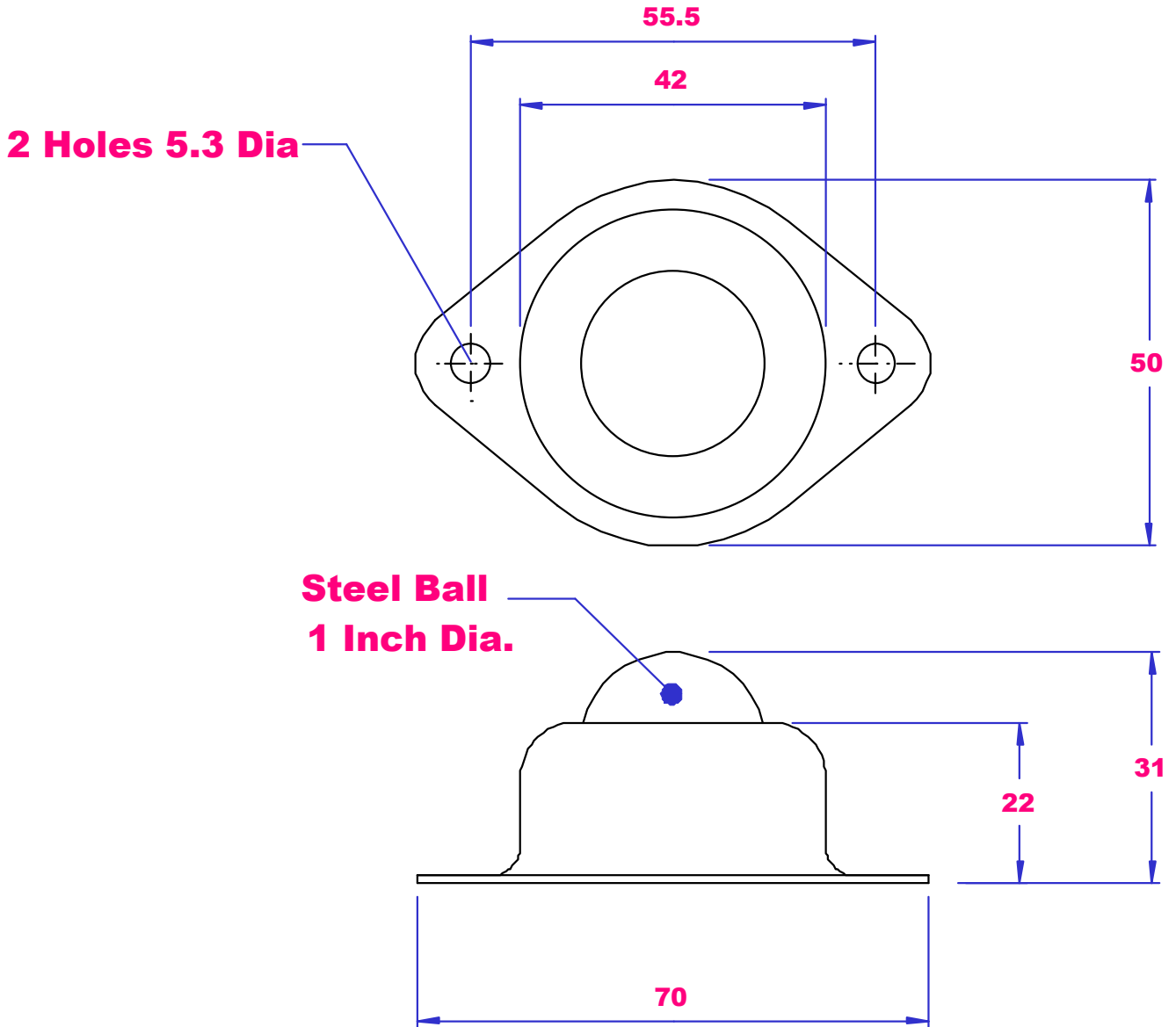

**MAXIMUM LOAD
50KG**



UBC

CONVEYOR ROLLER BEARING END CAPS

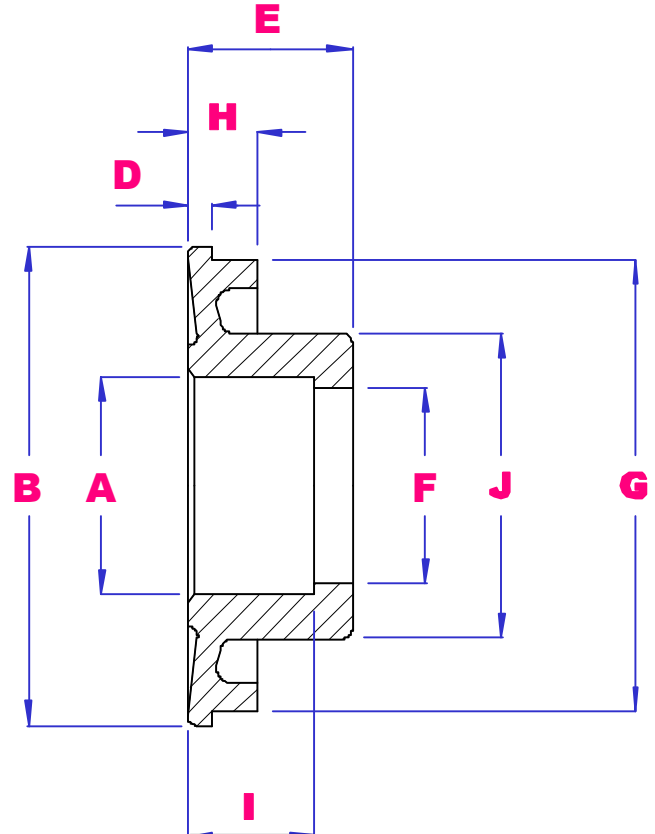
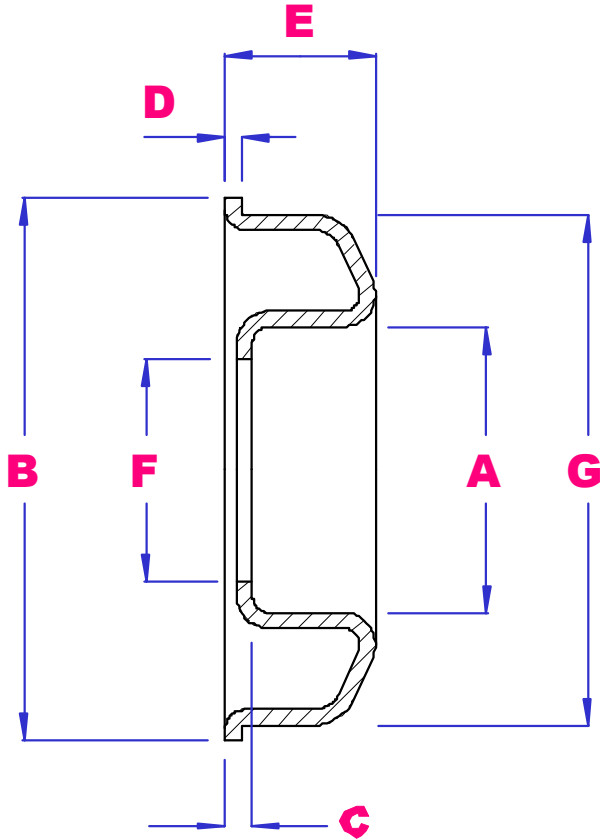

TYPE 1 PRESSED STEEL ZINC PLATED.
TYPE 1A INJECTION MOULDED NYLON.

TYPE 2 MACHINED CAST IRON.

PART NO	TYPE	A	B	C	D	E	F	G	H	I	J
RLR51	1A	35	50.1	3.2	2.1	15.3	22.5	46.5	-	-	-
SH72361P	1	47	76	4	2.1	23.5	36.5	72	-	-	-
SH83361P	1	47	88.1	4	2.1	23.5	36.5	83	-	-	-
CH205-4	2	52	101.6	-	5	35	41.5	95.7	15	27	65
CH205-4.5	2	52	114.3	-	5	35	41.5	108.4	15	27	65
CH205-5	2	52	127	-	5	35	41.5	121.1	15	27	65

AVAILABLE BEARING BORES A = 35

10, 12, 14, 15, 16, 17MM, 3/8", 1/2", 5/8".
8MM OVAL, 3/8, 7/16, 9/16 HEX,

AVAILABLE BEARING BORES A = 47

12, 14, 15, 17, 20, 25, 30, 35. 1/2", 5/8", 3/4", 7/8", 1"
8MM OVAL, 3/8, 7/16, 5/8, 11/16 HEX.

AVAILABLE BEARING BORES A = 52

20, 25, 28MM. 3/4", 7/8", 15/16", 1". 1" HEX



UBC

CONVEYOR ROLLER DRIVE SPROCKETS



Quality
Endorsed
Company
ISO 9001:2000
LIC QEC20818

500 SERIES SS62122

1/2" BS 14T00TH

AVAILABLE BEARING BORES
10MM, 12MM, 13MM, 14MM,
15MM, 16MM, 17MM.

3/8", 1/2", 5/8".

3/8" HEX, 7/16" HEX,
8MM OVAL.

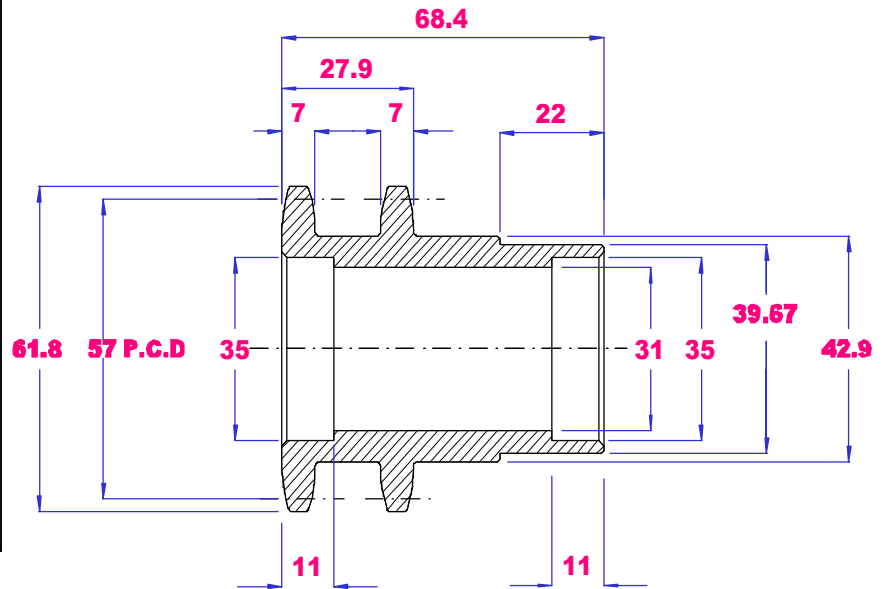

510 SERIES SS83253

5/8" BS 15 TOOTH

AVAILABLE BEARING BORES
15MM, 17MM, 20MM, 25MM,
30MM, 35MM.

1/2", 5/8", 3/4", 7/8", 1".

3/8" HEX, 7/16" HEX,
5/8" HEX, 11/16" HEX.

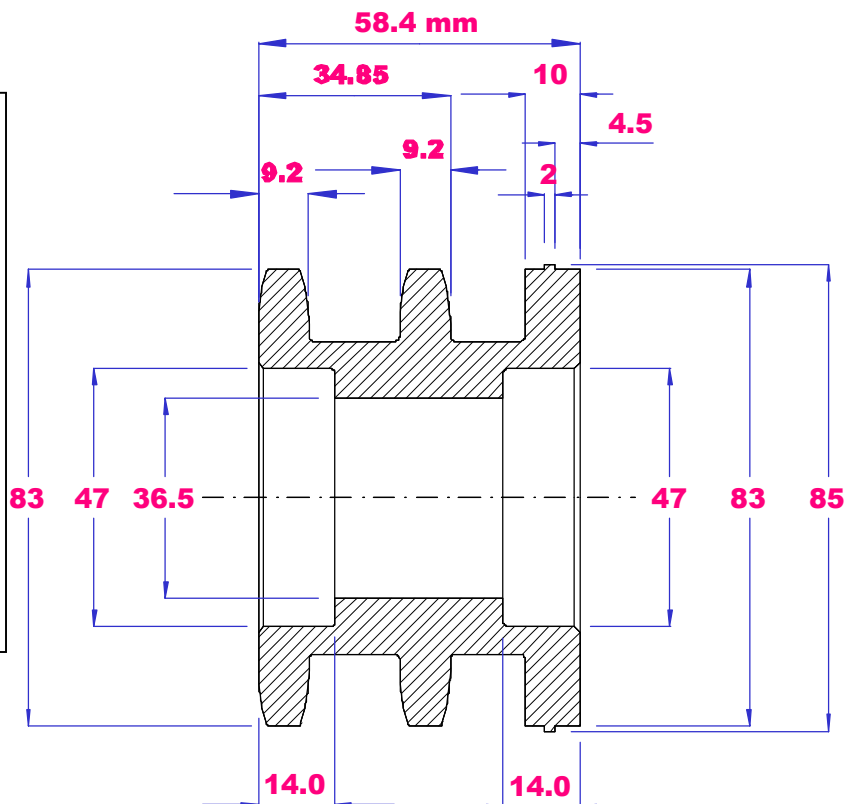



UBC CHAIN



Quality
Endorsed
Company
ISO 9001:2000
LIC QEC20818

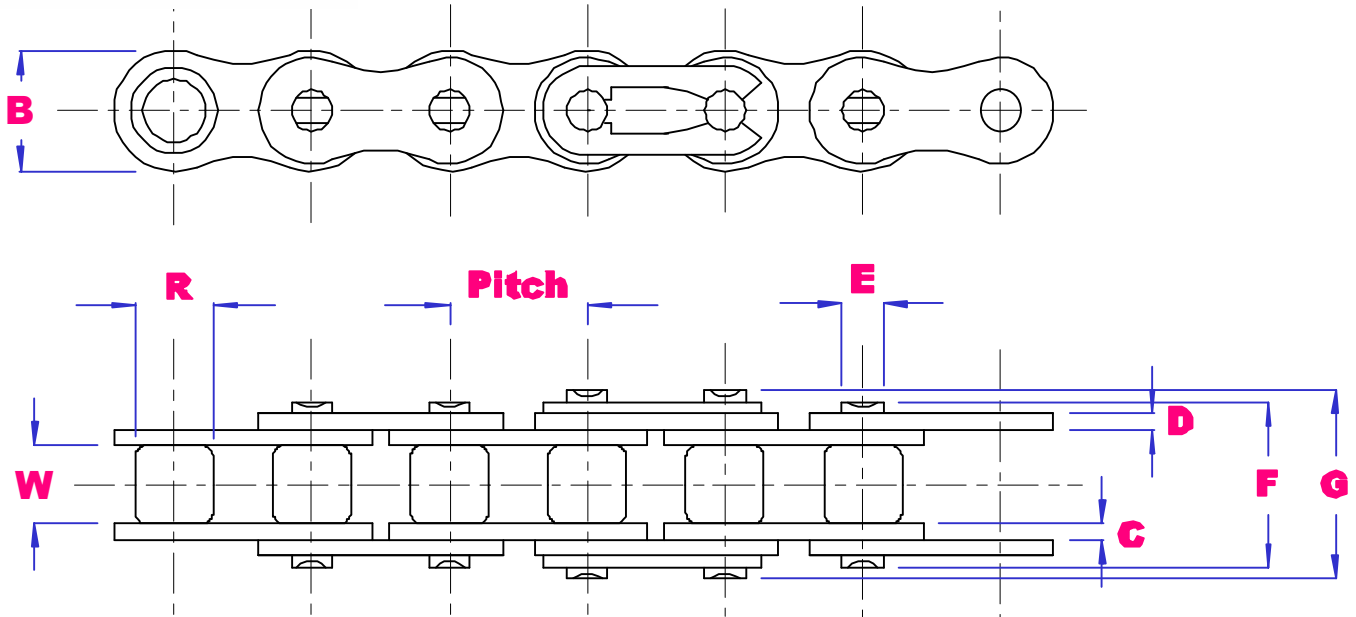

PART NO	Pitch		W mm	R mm	B mm	C mm	D mm	E mm	F mm	G mm	Av kgf	Wgt kg/m
	inch	mm										
25H-1	1/4	6.35	3.18	3.3	6.0	1.0	1.0	2.31	8.9	9.5	560	0.16
06B	3/8	9.525	5.72	6.35	8.2	1.0	1.25	3.28	13.2	14.1	1050	0.39
06BH	3/8	9.525	5.72	6.35	8.2	1.6	1.6	3.28	14.3	15.3	1580	0.48
35-1	3/8	9.525	4.77	5.08	9.0	1.3	1.3	3.58	12.4	13.2	1080	0.33
08B	1/2	12.7	7.75	8.51	11.8	1.5	1.5	4.44	16.7	18.2	1850	0.65
08B-2	1/2	12.7	7.75	8.51	11.8	1.5	1.5	4.44	31.2	32.2	3600	1.31
41-1	1/2	12.7	6.25	7.77	9.91	1.3	1.3	3.58	13.8	15.0	1260	0.41
40-1	1/2	12.7	7.85	7.95	12.0	1.5	1.5	3.96	16.6	17.8	1750	0.62
10B	5/8	15.88	9.65	10.16	14.7	1.65	1.65	5.08	19.2	20.9	2700	0.92
50-1	5/8	15.88	9.4	10.16	15.1	2.03	2.03	5.08	20.7	22.2	2940	1.02
12B	3/4	19.05	11.68	12.07	16.0	1.8	1.8	5.72	22.2	24.2	3300	1.24
60-1	3/4	19.05	12.57	11.91	18.0	2.42	2.42	5.94	25.9	27.7	4150	1.50
C2060H	1.1/2	38.1	12.7	11.91	17.1	3.1	3.1	5.95	28.2	29.8	5300	1.45
16B	1	25.4	17.02	15.88	21.0	3.1	4.15	8.28	36.1	37.4	7280	2.71
80-1	1	25.4	15.75	15.88	24.0	3.25	3.25	7.92	32.7	35.0	6940	2.60



UBC

UNIVERSAL JOINTS

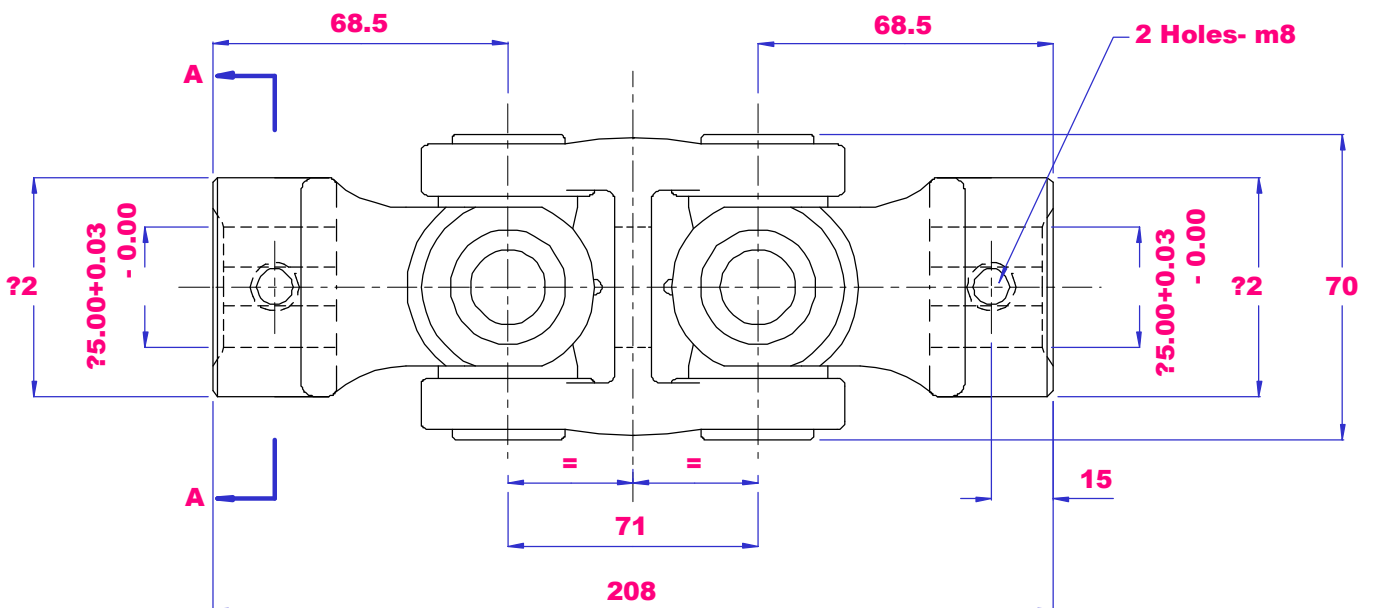
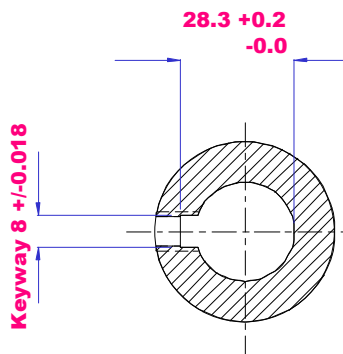
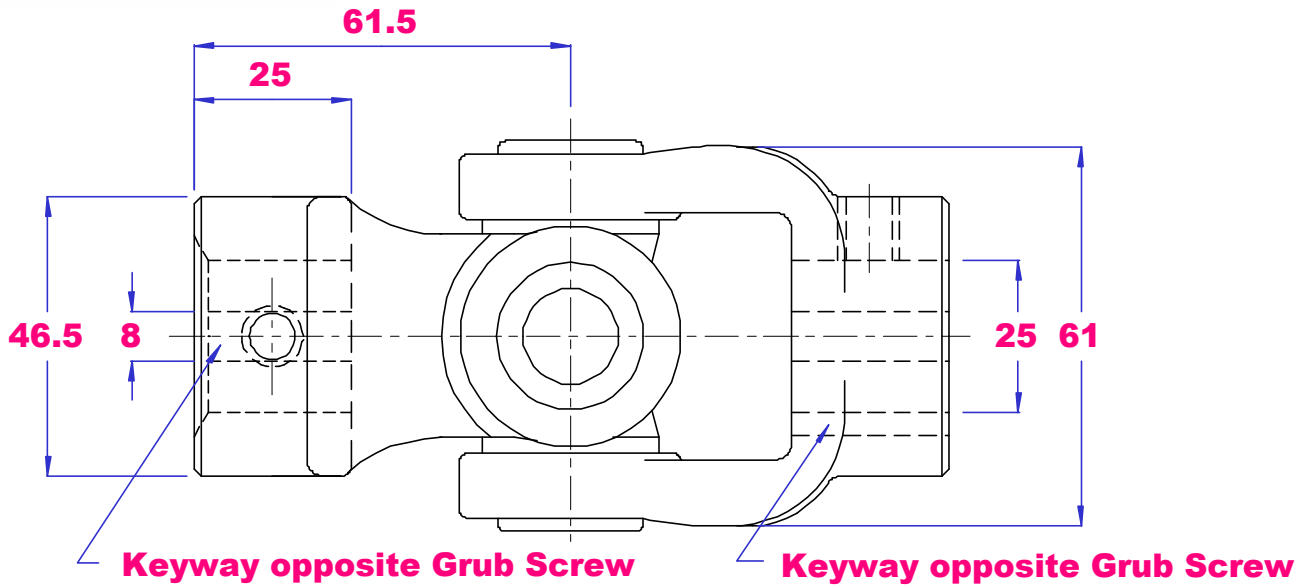



UBC

CHAIN COUPLING

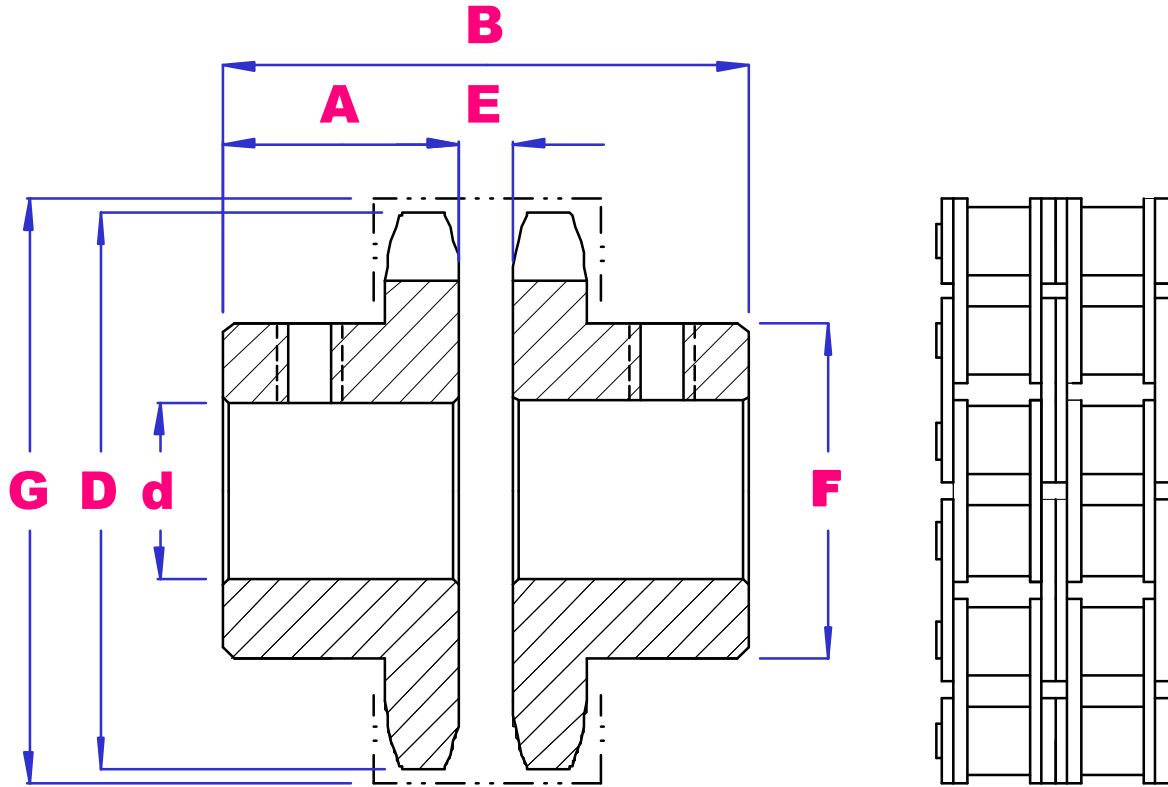

PART NO	d mm	D mm	A mm	B mm	E mm	F mm	G mm	KEY mm	Wgt sprocket	Wgt chain
08B-18-20	20	78	28	63	7	56	84.8	6x6	526	311
08B-18-25	25	78	28	63	7	56	84.8	8x7	491	311

SPROCKET MATERIAL: MILD STEEL ZINC PLATED



UBC

SELF ALIGNING WASHERS

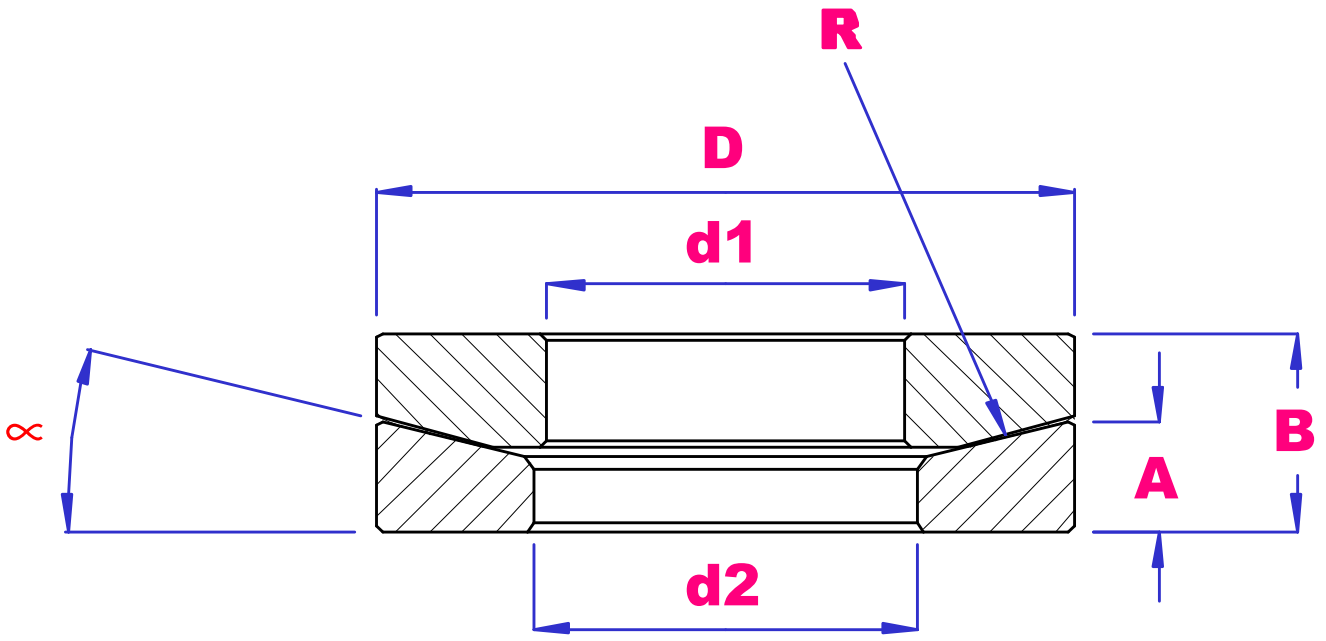

PART NO	Suit Bolt	d1	d2	D	A	B	C	R radius	α deg	Wgt g
SAW-6	3/8"- 10mm	12	15	22	5.0	6.0	4.0	18	30	11
SAW-8	1/2"- 12mm	14	16.5	26	6.0	8.0	5.0	20	30	22
SAW-10	5/8"- 16mm	17	19	30	6.3	9.5	5.0	23	30	31
SAW-12	3/4"- 20mm	21	23.3	36	7.4	11.5	6.0	27	30	54
SAW-14	7/8"- 22mm	23.0	24.6	45	8.0	14.3	8.3	63.5	14	126
SAW-16	1" - 24mm	26.2	27.8	50.8	8.0	14.3	8.3	80	14	158



UBC

METRIC SHAFT COLLARS

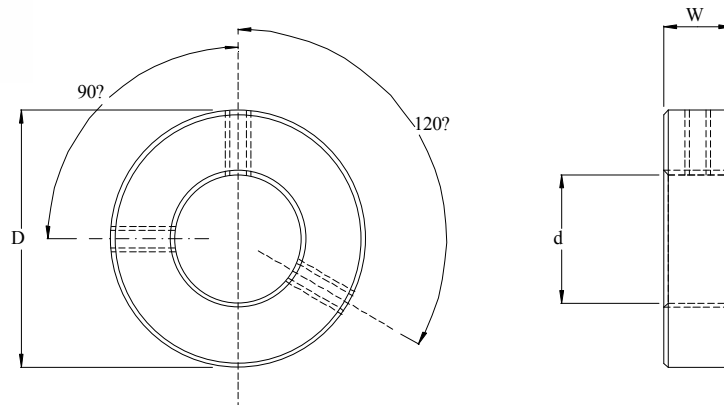

SCM-06, 08, 10 GRUB SCREWS @ 120 DEG
 SCM-12 – SCM-50 GRUB SCREWS @ 90 DEG

PART NO	d mm	D mm	W mm	Screw x 2	Weight gm
SCM-06	6	22.2	13.5	M5x0.8	36
SCM-08	8	22.2	13.5	M5x0.8	35
SCM-10	10	22.2	13.5	M5x0.8	32
SCM-12	12	28.6	13.5	M6x1	52
SCM-14	14	28.6	13.5	M6x1	50
SCM-16	16	28.6	13.5	M6x1	45
SCM-20	20	33.3	13.5	M6x1	56
SCM-22	22	38.1	13.5	M6x1	77
SCM-24	24	44.5	15.9	M8x1	130
SCM-25	25	44.5	15.9	M8x1	128
SCM-28	28	44.5	15.9	M8x1	113
SCM-30	30	44.5	15.9	M8x1	102
SCM-32	32	55.5	17.5	M8x1	214
SCM-35	35	55.5	17.5	M8x1	192
SCM-38	38	63.5	18.3	M10x1.25	238
SCM-40	40	63.5	18.3	M10x1.25	265
SCM-42	42	63.5	18.3	M10x1.25	247
SCM-45	45	69.9	18.3	M10x1.25	309
SCM-48	48	76.2	20.0	M10x1.25	431
SCM-50	50	76.2	20.0	M10x1.25	405
SCM-60	60	92	20.0	M10X1.25	540
SCM-70	70	101.5	20.0	M10X1.25	607
SCM-75	75	101.5	22.2	M12X1.5	845

**MATERIAL = MILD STEEL
 ZINC PLATED**

**TOLERANCE = d – 0.01 + 0.01mm
 D – 0.1 + 0.1 mm
 W – 0.1 + 0.1 mm**



UBC

INCH SHAFT COLLARS

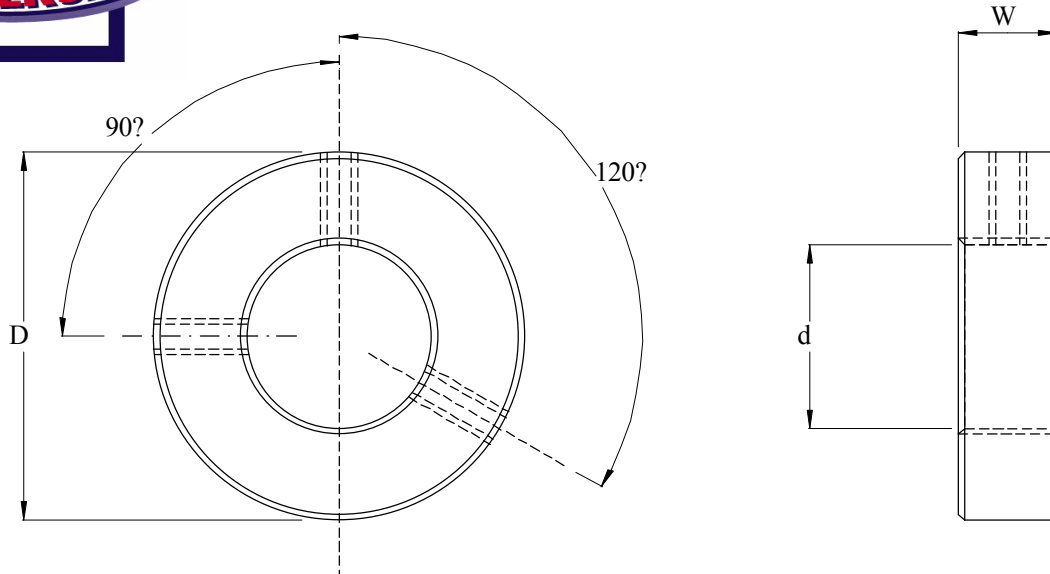

SCI-1/4, 5/16, 3/8 GRUB SCREWS @ 120 DEG
 SCI-7/16 – SCI-2 GRUB SCREWS @90 DEG

PART NO	d in	D in	W mm	Screw x 2	Weight gm
SCI-1/4	0.25	0.875	13.5	M5X0.8	37
SCI-5/16	0.3125	0.875	13.5	M5X0.8	35
SCI-3/8	0.375	0.875	13.5	M5X0.8	32
SCI-7/16	0.4375	1.125	13.5	M6x1	55
SCI-1/2	0.50	1.125	13.5	M6x1	52
SCI-5/8	0.625	1.125	13.5	M6x1	45
SCI-3/4	0.75	1.312	13.5	M6x1	60
SCI-7/8	0.875	1.50	13.5	M6x1	76
SCI-1	1.00	1.75	15.9	M8x1	126
SCI-1.1/8	1.125	1.75	15.9	M8x1	110
SCI-1.1/4	1.25	2.187	17.5	M8x1	216
SCI-1.3/8	1.375	2.187	17.5	M8x1	193
SCI-1.1/2	1.5	2.375	18.3	M8x1	237
SCI-1.5/8	1.625	2.50	18.3	M8x1	253
SCI-1.3/4	1.75	2.75	18.3	M10x1.25	313
SCI-2	2.00	3.00	20.7	M10x1.25	398
SCI-2.1/4	2.25	3.375	23.8	M10X1.25	494
SCI-2.1/2	2.50	3.625	25.4	M10X1.25	573
SCI-3	3.00	4.00	28.6	M12X1.5	967

**MATERIAL = MILD STEEL
 ZINC PLATED**

**TOLERANCE = d – 0.01 + 0.01mm
 D – 0.1 + 0.1 mm
 W – 0.1 + 0.1 mm**

INCHES – MILLIMETERS

INCHES		0	1	2	3	4	5	6	7	8	9	10
FRACTION	DECIMAL	MILLIMETERS										
0	0.00000	0.000	25.400	50.800	76.200	101.600	127.000	152.400	177.800	203.200	228.600	254.000
1/64	0.015625	0.397	25.797	51.197	76.597	101.997	127.397	152.797	178.197	203.597	228.997	254.397
1/32	0.031250	0.794	26.194	51.594	76.994	102.394	127.794	153.194	178.594	203.994	229.394	254.794
3/64	0.046875	1.191	26.591	51.991	77.391	102.791	128.191	153.591	178.991	204.391	229.791	255.191
1/16	0.062500	1.588	26.988	52.388	77.788	103.188	128.588	153.988	179.388	204.788	230.188	255.588
5/64	0.078125	1.984	27.384	52.784	78.184	103.584	128.984	154.384	179.784	205.184	230.584	255.984
3/32	0.093750	2.381	27.781	53.181	78.581	103.981	129.381	154.781	180.181	205.581	230.981	256.381
7/64	0.109375	2.778	28.178	53.578	78.978	104.378	129.778	155.178	180.578	205.978	231.378	256.778
1/8	0.125000	3.175	28.575	53.975	79.375	104.775	130.175	155.575	180.975	206.375	231.775	257.175
9/64	0.140625	3.572	28.973	54.372	79.772	105.172	130.572	155.972	181.372	206.772	232.172	257.572
5/32	0.156250	3.969	29.369	54.769	80.169	105.569	130.969	156.369	181.769	207.169	232.569	257.969
11/64	0.171875	4.366	29.766	55.166	80.566	105.966	131.366	156.766	182.166	207.566	232.966	258.366
3/16	0.187500	4.762	30.163	55.563	80.963	106.363	131.763	157.163	182.563	207.963	233.363	258.763
13/64	0.203125	5.159	30.559	55.959	81.359	106.759	132.159	157.559	182.959	208.359	233.759	259.159
7/32	0.218750	5.556	30.956	56.356	81.756	107.156	132.556	157.956	183.356	208.756	234.156	259.556
15/64	0.234375	5.953	31.353	56.753	82.153	107.553	132.953	158.353	183.753	209.153	234.553	259.953
1/4	0.250000	6.350	31.750	57.150	82.550	107.950	133.350	158.750	184.150	209.550	234.950	260.350
17/64	0.265625	6.747	32.147	57.547	82.947	108.347	133.747	159.147	184.547	209.947	235.347	260.747
9/32	0.281250	7.144	32.544	57.944	83.344	108.744	134.144	159.544	184.944	210.344	235.744	261.144
19/64	0.296875	7.541	32.941	58.341	83.741	109.141	134.541	159.941	185.341	210.741	236.141	261.541
5/16	0.312500	7.938	33.338	58.738	84.138	109.538	134.938	160.338	185.738	211.138	236.538	261.938
21/64	0.328125	8.334	33.734	59.134	84.534	109.934	135.334	160.734	186.134	211.534	236.934	262.334
11/32	0.343750	8.731	34.131	59.531	84.931	110.331	135.731	161.131	186.531	211.931	237.331	262.731
23/64	0.359375	9.128	34.528	59.928	85.328	110.728	136.128	161.528	186.928	212.328	237.728	263.128
3/8	0.375000	9.525	34.925	60.325	85.725	111.125	136.525	161.925	187.325	212.725	238.125	263.525
25/64	0.390625	9.922	35.322	60.722	86.122	111.522	136.922	162.322	187.722	213.122	238.522	263.922
13/32	0.406250	10.319	35.719	61.119	86.519	111.919	137.319	162.719	188.119	213.519	238.919	264.319
27/64	0.421875	10.716	36.116	61.516	86.916	112.316	137.716	163.116	188.516	213.916	239.316	264.716
7/16	0.437500	11.113	36.513	61.913	87.313	112.713	138.113	163.513	188.913	214.313	239.713	265.113
29/64	0.453125	11.509	36.909	62.309	87.709	113.109	138.509	163.909	189.309	214.709	240.109	265.509
15/32	0.468750	11.906	37.306	62.706	88.106	113.506	138.906	164.306	189.706	215.106	240.506	265.906
31/32	0.484375	12.303	37.703	63.103	88.503	113.903	139.303	164.703	190.103	215.503	240.903	266.303
1/2	0.500000	12.700	38.100	63.500	88.900	114.300	139.700	165.100	190.500	215.900	241.300	266.700
33/64	0.515625	13.097	38.497	63.897	89.297	114.697	140.097	165.495	190.897	216.297	241.697	267.097
17/32	0.531250	13.494	38.894	64.294	89.694	115.094	140.494	165.894	191.294	216.694	242.094	267.494
35/64	0.546875	13.891	39.291	64.691	90.091	115.491	140.891	166.291	191.691	217.091	242.491	267.891
9/16	0.562500	14.288	39.688	65.088	90.488	115.888	141.288	166.688	192.088	217.488	242.888	268.288
37/64	0.578125	14.684	40.084	65.484	90.884	116.284	141.684	167.084	192.484	217.884	243.284	268.684
19/32	0.593750	15.081	40.481	65.881	91.281	116.681	142.081	167.481	192.881	218.281	243.681	269.081
39/64	0.609375	15.478	40.878	66.278	91.678	117.078	142.478	167.878	193.278	218.678	244.078	269.478
5/8	0.625000	15.875	41.275	66.675	92.075	117.475	142.875	168.275	193.675	219.075	244.475	269.875
41/64	0.640625	16.272	41.672	67.072	92.472	117.872	143.272	168.672	194.072	219.472	244.872	270.272
21/32	0.656250	16.669	42.069	67.469	92.869	118.269	143.669	169.069	194.469	219.869	245.269	270.669
43/64	0.671875	17.066	42.466	67.866	93.266	118.666	144.066	169.466	194.866	220.266	245.666	271.066
11/16	0.687500	17.463	42.863	68.263	93.663	119.063	144.463	169.863	195.263	220.663	246.063	271.463
45/64	0.703125	17.859	43.259	68.659	94.059	119.459	144.859	170.259	195.659	221.059	246.459	271.859
23/32	0.718750	18.256	43.656	69.056	94.456	119.856	145.256	170.656	196.056	221.456	246.856	272.256
47/64	0.734375	18.653	44.053	69.453	94.853	120.253	145.653	171.053	196.453	221.853	247.253	272.653
3/4	0.750000	19.050	44.450	69.850	95.250	120.650	146.050	171.450	196.850	222.250	247.650	273.050
49/64	0.765625	19.447	44.847	70.247	95.647	121.047	146.447	171.847	197.247	222.647	248.047	273.447
25/32	0.781250	19.844	45.244	70.644	96.044	121.444	146.844	172.244	197.644	223.044	248.444	273.844
51/64	0.796875	20.241	45.641	71.041	96.441	121.841	147.241	172.641	198.041	223.441	248.841	274.241
13/16	0.812500	20.638	46.038	71.438	96.838	122.238	147.638	173.038	198.438	223.838	249.238	274.638
53/64	0.828125	21.034	46.434	71.834	97.234	122.634	148.034	173.434	198.834	224.234	249.634	275.034
27/32	0.843750	21.431	46.831	72.231	97.631	123.031	148.431	173.831	199.231	224.631	250.031	275.431
55/64	0.859375	21.828	47.228	72.628	98.028	123.428	148.828	174.228	199.628	225.028	250.428	275.828
7/8	0.875000	22.225	47.625	73.025	98.425	123.825	149.225	174.625	200.025	225.425	250.825	276.225
57/64	0.890625	22.622	48.022	73.422	98.822	124.222	149.622	175.022	200.422	225.822	251.222	276.622
29/32	0.906250	23.019	48.419	73.819	99.219	124.619	150.019	175.419	200.819	226.219	251.619	277.019
59/64	0.921875	23.416	48.816	74.216	99.616	125.016	150.416	175.816	201.216	226.616	252.016	277.416
15/16	0.937500	23.813	49.213	74.613	100.013	125.413	150.813	176.213	201.613	227.013	252.413	277.813
61/64	0.953125	24.209	49.609	75.009	100.409	125.809	151.209	176.609	202.009	227.409	252.809	278.209
31/32	0.968750	24.606	50.006	75.406	100.806	126.206	151.606	177.006	202.406	227.806	253.206	278.606
63/64	0.984375	25.003	50.403	75.803	101.203	126.603	152.003	177.403	202.803	228.203	253.603	279.003



MILLIMETERS - - INCHES



MM	0	10	20	30	40	50	60	70	80	90
0	0.00000	0.39370	0.78740	1.18110	1.57480	1.96850	2.36220	2.75591	3.14961	3.54331
1	0.03937	0.43307	0.82677	1.22047	1.61417	2.00787	2.40157	2.79528	3.18898	3.58268
2	0.07874	0.47244	0.86614	1.25984	1.65354	2.04724	2.44094	2.83465	3.22835	3.62205
3	0.11811	0.51181	0.90551	1.29921	1.69291	2.08661	2.48031	2.87402	3.26772	3.66142
4	0.15748	0.55118	0.94488	1.33858	1.73228	2.12598	2.51969	2.91339	3.30709	3.70079
5	0.19685	0.59055	0.98425	1.37795	1.77165	2.16535	2.55906	2.95276	3.34646	3.74016
6	0.23622	0.62992	1.02362	1.41732	1.81102	2.20472	2.59843	2.99213	3.38583	3.77953
7	0.27559	0.66929	1.06299	1.45669	1.85039	2.24409	2.63780	3.03150	3.42520	3.81890
8	0.31496	0.70866	1.10236	1.49606	1.88976	2.28346	2.67717	3.07087	3.46457	3.85827
9	0.35433	0.74803	1.14173	1.53543	1.92913	2.32283	2.71653	3.11024	3.50394	3.89764

MM = INCH		MM = INCH		MM = INCH	
0.001	0.000039	0.01	0.000393	0.1	0.003937
0.002	0.000079	0.02	0.000787	0.2	0.007874
0.003	0.000118	0.03	0.001811	0.3	0.011811
0.004	0.000157	0.04	0.001575	0.4	0.015748
0.005	0.000197	0.05	0.001969	0.5	0.019685
0.006	0.000236	0.06	0.002362	0.6	0.023622
0.007	0.000276	0.07	0.002756	0.7	0.027559
0.008	0.000315	0.08	0.003150	0.8	0.031496
0.009	0.000354	0.09	0.003543	0.9	0.035433

MM	100	150	200	250	300	350
0	3.93701	5.90551	7.87402	9.84252	11.8110	13.7795
5	4.13386	6.10236	8.07087	10.0394	12.0079	13.9764
10	4.33071	6.29921	8.26772	10.2362	12.2047	14.1732
15	4.52756	6.49606	8.46457	10.4331	12.4016	14.3701
20	4.72441	6.69291	8.66142	10.6299	12.5984	14.5669
25	4.92126	6.88976	8.85827	10.8268	12.7953	14.7638
30	5.11811	7.09661	9.05512	11.0236	12.9921	14.9606
35	5.31496	7.28346	9.25197	11.2205	13.1890	15.1575
40	5.51181	7.48031	9.44882	11.4137	13.3858	15.3543
45	5.70866	7.67716	9.64567	11.6142	13.5827	15.5512