

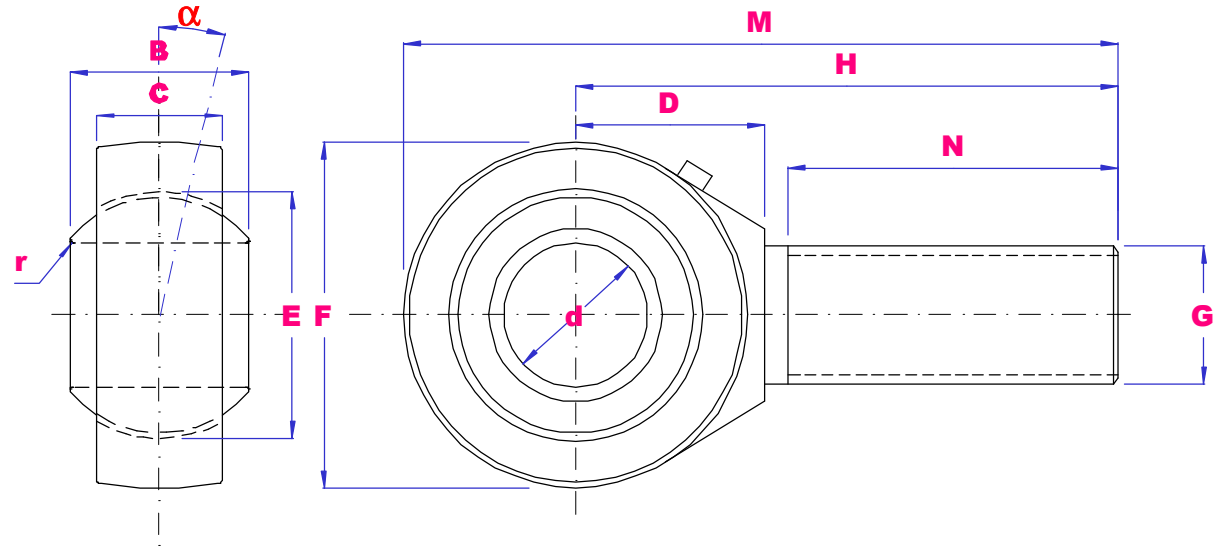

INCH MALE ROD ENDS STEEL / BRONZE



PART NO	d	B	E	C	F	G UNF	H	N	M	D	r	α deg	Load kN		Wgt g
													Dyn	Stat	
SAZP4S	4.83	7.92	11.11	6.35	15.88	10-32	31.75	19.05	39.7	-	0.3	10	3.4	3.8	13
	0.187	0.312	0.437	0.25	0.625		1.25	0.75	1.563	-	0.012				
SAZP6S	6.35	9.53	12.7	7.14	19.05	1/4-28	39.67	25.4	49.2	-	0.3	13	4.5	6.6	22
	0.25	0.375	0.50	0.281	0.75		1.562	1.00	1.937	-	0.012				
SAZP7S	7.94	11.11	15.88	8.74	22.23	5/16-24	47.63	31.75	58.72	-	0.3	10	6.9	8.4	37
	0.312	0.437	0.625	0.344	0.875		1.875	1.25	2.312	-	0.012				
SAZP9S	9.53	12.7	18.26	10.31	25.4	3/8-24	49.23	31.75	61.93	-	0.3	9	9.4	10	55
	0.375	0.50	0.719	0.406	1.00		1.938	1.25	2.438	-	0.012				
SAZP11S	11.11	14.27	20.62	11.11	28.58	7/16-20	53.98	34.93	68.28	-	0.6	11	11	13	78
	0.437	0.562	0.812	0.437	1.125		2.125	1.375	2.688	-	0.024				
SAZP12S	12.7	15.88	23.81	12.7	33.32	1/2-20	61.93	38.1	78.59	-	0.6	9	15	19	120
	0.50	0.625	0.937	0.50	1.312		2.438	1.50	3.094	-	0.024				
SAZP15S	15.88	19.05	28.58	14.27	38.1	5/8-18	66.68	41.28	85.73	18.2	0.6	11	20	21	180
	0.625	0.75	1.125	0.562	1.50		2.625	1.625	3.375	0.717	0.024				
SAZP19S	19.05	22.23	33.32	17.45	44.45	3/4-16	73.03	44.45	95.25	20.9	0.6	10	29	29	290
	0.75	0.875	1.312	0.687	1.75		2.875	1.75	3.75	0.823	0.024				
SAZP25S	25.4	34.93	47.63	25.4	69.85	1.1/4-12	104.78	53.98	139.7	33.9	0.6	14	60	101	1100
	1.00	1.375	1.875	1.00	2.75		4.125	2.125	5.50	1.335	0.024				

THE FULL RANGE IS AVAILABLE IN LEFT HAND THREAD USE PART NO SALZP-S