

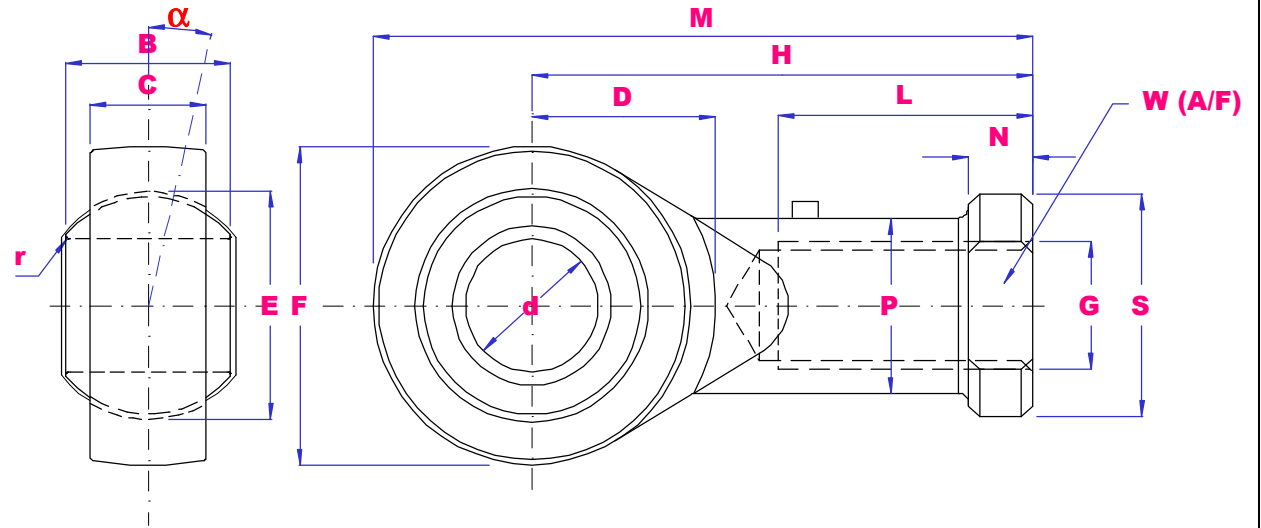

INCH FEMALE RODENDS STEEL / TEFLON



PART NO	d	B	E	C	F	G UNF	H	L	M	N	D	W	P	S	r min	α deg	Load kN		Wgt g
																	Dyn	Stat	
SIZK4	4.83	7.92	11.11	5.94	19.05	10-32	26.97	12.7	34.93	4.75	9	7.92	7.54	10.31	0.3	4	3.6	4.6	24
	0.187	0.312	0.437	0.234	0.75		1.062	0.5	1.375	0.187	0.354	0.312	0.297	0.406	0.012				
SIZK6	6.35	9.53	12.7	6.35	21.2	1/4-28	33.32	15.88	42.85	4.75	10.5	9.53	9.15	11.91	0.3	9	4.7	5.2	36
	0.25	0.375	0.5	0.25	0.83		1.312	0.625	1.687	0.187	0.413	0.375	0.36	0.496	0.012				
SIZK7	7.94	11.11	15.88	7.92	25.4	5/16-24	34.93	15.88	55.0	4.75	11.7	11.11	10.72	12.7	0.3	12	7.6	8.2	48
	0.312	0.437	0.625	0.312	1.00		1.375	0.625	1.812	0.187	0.461	0.437	0.422	0.50	0.012				
SIZK9	9.53	12.7	18.26	9.12	31.1	3/8-24	41.28	19.05	53.98	6.35	12.3	14.27	13.89	17.45	0.6	12	12	15	59
	0.375	0.5	0.719	0.359	1.23		1.625	0.75	2.125	0.25	0.484	0.562	0.547	0.687	0.024				
SIZK11	11.11	14.27	20.62	10.31	33.1	7/16-20	46.02	22.23	60.33	6.35	14	15.88	15.49	19.05	0.6	14	14	19	91
	0.437	0.562	0.812	0.406	1.31		1.812	0.875	2.375	0.25	0.551	0.625	0.61	0.75	0.024				
SIZK12	12.7	15.88	23.81	11.5	34.2	1/2-20	53.98	25.4	70.64	6.35	16.2	19.05	18.67	22.23	0.6	14	15	26	113
	0.5	0.625	0.937	0.453	1.346		2.125	1.00	2.781	0.25	0.638	0.75	0.735	0.875	0.024				
SIZK15	15.88	19.05	28.58	12.29	42.7	5/8-18	63.50	31.75	82.55	7.92	18.2	22.23	21.84	25.4	0.6	19	23	29	195
	0.625	0.75	1.125	0.484	1.68		2.50	1.25	3.25	0.312	0.717	0.875	0.86	1.00	0.024				
SIZK19	19.05	22.23	33.32	15.06	44.45	3/4-16	73.03	34.93	95.25	7.92	20.9	25.4	25.02	28.58	0.6	15	34	40	295
	0.75	0.875	1.312	0.593	1.75		2.875	1.375	3.75	0.312	0.823	1.00	0.985	1.125	0.024				

THE FULL RANGE IS AVAILABLE IN LEFT HAND THREAD USE PART NO SILZJ